



**BUREAU
VERITAS**

Rules for the Classification of Floating Storage Regasification Units

October 2017

**Rule Note
NR 645 DT R00 E**



**BUREAU
VERITAS**

MARINE & OFFSHORE - GENERAL CONDITIONS

1. INDEPENDENCY OF THE SOCIETY AND APPLICABLE TERMS

- 1.1. The Society shall remain at all times an independent contractor and neither the Society nor any of its officers, employees, servants, agents or subcontractors shall be or act as an employee, servant or agent of any other party hereto in the performance of the Services.
- 1.2. The operations of the Society in providing its Services are exclusively conducted by way of random inspections and do not, in any circumstances, involve monitoring or exhaustive verification.
- 1.3. The Society acts as a services provider. This cannot be construed as an obligation bearing on the Society to obtain a result or as a warranty. The Society is not and may not be considered as an underwriter, broker in Unit's sale or chartering, expert in Unit's valuation, consulting engineer, controller, naval architect, manufacturer, shipbuilder, repair or conversion yard, charterer or shipowner; none of them above listed being relieved of any of their expressed or implied obligations as a result of the interventions of the Society.
- 1.4. The Services are carried out by the Society according to the applicable Rules and to the Bureau Veritas' Code of Ethics. The Society only is qualified to apply and interpret its Rules.
- 1.5. The Client acknowledges the latest versions of the Conditions and of the applicable Rules applying to the Services' performance.
- 1.6. Unless an express written agreement is made between the Parties on the applicable Rules, the applicable Rules shall be the rules applicable at the time of the Services' performance and contract's execution.
- 1.7. The Services' performance is solely based on the Conditions. No other terms shall apply whether express or implied.

2. DEFINITIONS

- 2.1. "**Certificate(s)**" means class certificates, attestations and reports following the Society's intervention. The Certificates are an appraisal given by the Society to the Client, at a certain date, following surveys by its surveyors on the level of compliance of the Unit to the Society's Rules or to the documents of reference for the Services provided. They cannot be construed as an implied or express warranty of safety, fitness for the purpose, seaworthiness of the Unit or of its value for sale, insurance or chartering.
- 2.2. "**Certification**" means the activity of certification in application of national and international regulations or standards, in particular by delegation from different governments that can result in the issuance of a certificate.
- 2.3. "**Classification**" means the classification of a Unit that can result or not in the issuance of a class certificate with reference to the Rules.
- 2.4. "**Client**" means the Party and/or its representative requesting the Services.
- 2.5. "**Conditions**" means the terms and conditions set out in the present document.
- 2.6. "**Industry Practice**" means International Maritime and/or Offshore industry practices.
- 2.7. "**Intellectual Property**" means all patents, rights to inventions, utility models, copyright and related rights, trade marks, logos, service marks, trade dress, business and domain names, rights in trade dress or get-up, rights in goodwill or to sue for passing off, unfair competition rights, rights in designs, rights in computer software, database rights, topography rights, moral rights, rights in confidential information (including know-how and trade secrets), methods and protocols for Services, and any other intellectual property rights, in each case whether capable of registration, registered or unregistered and including all applications for and renewals, reversions or extensions of such rights, and all similar or equivalent rights or forms of protection in any part of the world.
- 2.8. "**Parties**" means the Society and Client together.
- 2.9. "**Party**" means the Society or the Client.
- 2.10. "**Register**" means the register published annually by the Society.
- 2.11. "**Rules**" means the Society's classification rules, guidance notes and other documents. The Rules, procedures and instructions of the Society take into account at the date of their preparation the state of currently available and proven technical minimum requirements but are not a standard or a code of construction neither a guide for maintenance, a safety handbook or a guide of professional practices, all of which are assumed to be known in detail and carefully followed at all times by the Client.
- 2.12. "**Services**" means the services set out in clauses 2.2 and 2.3 but also other services related to Classification and Certification such as, but not limited to: ship and company safety management certification, ship and port security certification, training activities, all activities and duties incidental thereto such as documentation on any supporting means, software, instrumentation, measurements, tests and trials on board.
- 2.13. "**Society**" means the classification society "**Bureau Veritas Marine & Offshore SAS**", a company organized and existing under the laws of France, registered in Nanterre under the number 821 131 844, or any other legal entity of Bureau Veritas Group as may be specified in the relevant contract, and whose main activities are Classification and Certification of ships or offshore units.
- 2.14. "**Unit**" means any ship or vessel or offshore unit or structure of any type or part of it or system whether linked to shore, river bed or sea bed or not, whether operated or located at sea or in inland waters or partly on land, including submarines, hovercrafts, drilling rigs, offshore installations of any type and of any purpose, their related and ancillary equipment, subsea or not, such as well head and pipelines, mooring legs and mooring points or otherwise as decided by the Society.

3. SCOPE AND PERFORMANCE

- 3.1. The Society shall perform the Services according to the applicable national and international standards and Industry Practice and always on the assumption that the Client is aware of such standards and Industry Practice.

- 3.2. Subject to the Services performance and always by reference to the Rules, the Society shall:

- review the construction arrangements of the Unit as shown on the documents provided by the Client;
- conduct the Unit surveys at the place of the Unit construction;
- class the Unit and enters the Unit's class in the Society's Register;
- survey the Unit periodically in service to note that the requirements for the maintenance of class are met. The Client shall inform the Society without delay of any circumstances which may cause any changes on the conducted surveys or Services.

The Society will not:

- declare the acceptance or commissioning of a Unit, nor its construction in conformity with its design, such activities remaining under the exclusive responsibility of the Unit's owner or builder;
- engage in any work relating to the design, construction, production or repair checks, neither in the operation of the Unit or the Unit's trade, neither in any advisory services, and cannot be held liable on those accounts.

4. RESERVATION CLAUSE

- 4.1. The Client shall always: (i) maintain the Unit in good condition after surveys; (ii) present the Unit after surveys; (iii) present the Unit for surveys; and (iv) inform the Society in due course of any circumstances that may affect the given appraisal of the Unit or cause to modify the scope of the Services.
- 4.2. Certificates referring to the Society's Rules are only valid if issued by the Society.
- 4.3. The Society has entire control over the Certificates issued and may at any time withdraw a Certificate at its entire discretion including, but not limited to, in the following situations: where the Client fails to comply in due time with instructions of the Society or where the Client fails to pay in accordance with clause 6.2 hereunder.

5. ACCESS AND SAFETY

- 5.1. The Client shall give to the Society all access and information necessary for the efficient performance of the requested Services. The Client shall be the sole responsible for the conditions of presentation of the Unit for tests, trials and surveys and the conditions under which tests and trials are carried out. Any information, drawings, etc. required for the performance of the Services must be made available in due time.
 - 5.2. The Client shall notify the Society of any relevant safety issue and shall take all necessary safety-related measures to ensure a safe work environment for the Society or any of its officers, employees, servants, agents or subcontractors and shall comply with all applicable safety regulations.
- ## 6. PAYMENT OF INVOICES
- 6.1. The provision of the Services by the Society, whether complete or not, involve, for the part carried out, the payment of fees thirty (30) days upon issuance of the invoice.
 - 6.2. Without prejudice to any other rights hereunder, in case of Client's payment default, the Society shall be entitled to charge, in addition to the amount not properly paid, interests equal to twelve (12) months LIBOR plus two (2) per cent as of due date calculated on the number of days such payment is delinquent. The Society shall also have the right to withhold certificates and other documents and/or to suspend or revoke the validity of certificates.
 - 6.3. In case of dispute on the invoice amount, the undisputed portion of the invoice shall be paid and an explanation on the dispute shall accompany payment so that action can be taken to solve the dispute.

7. LIABILITY

- 7.1. The Society bears no liability for consequential loss. For the purpose of this clause consequential loss shall include, without limitation:
 - Indirect or consequential loss;
 - Any loss and/or deferral of production, loss of product, loss of use, loss of bargain, loss of revenue, loss of profit or anticipated profit, loss of business and business interruption, in each case whether direct or indirect.

The Client shall save, indemnify, defend and hold harmless the Society from the Client's own consequential loss regardless of cause.

- 7.2. In any case, the Society's maximum liability towards the Client is limited to one hundred and fifty per-cents (150%) of the price paid by the Client to the Society for the performance of the Services. This limit applies regardless of fault by the Society, including breach of contract, breach of warranty, tort, strict liability, breach of statute.
- 7.3. All claims shall be presented to the Society in writing within three (3) months of the Services' performance or (if later) the date when the events which are relied on were first discovered by the Client. Any claim not so presented as defined above shall be deemed waived and absolutely time barred.

8. INDEMNITY CLAUSE

- 8.1. The Client agrees to release, indemnify and hold harmless the Society from and against any and all claims, demands, lawsuits or actions for damages, including legal fees, for harm or loss to persons and/or property tangible, intangible or otherwise which may be brought against the Society, incidental to, arising out of or in connection with the performance of the Services except for those claims caused solely and completely by the negligence of the Society, its officers, employees, servants, agents or subcontractors.

9. TERMINATION

- 9.1. The Parties shall have the right to terminate the Services (and the relevant contract) for convenience after giving the other Party thirty (30) days' written notice, and without prejudice to clause 6 above.

- 9.2. In such a case, the class granted to the concerned Unit and the previously issued certificates shall remain valid until the date of effect of the termination notice issued, subject to compliance with clause 4.1 and 6 above.

10. FORCE MAJEURE

- 10.1. Neither Party shall be responsible for any failure to fulfil any term or provision of the Conditions if and to the extent that fulfilment has been delayed or temporarily prevented by a force majeure occurrence without the fault or negligence of the Party affected and which, by the exercise of reasonable diligence, the said Party is unable to provide against.
- 10.2. For the purpose of this clause, force majeure shall mean any circumstance not being within a Party's reasonable control including, but not limited to: acts of God, natural disasters, epidemics or pandemics, wars, terrorist attacks, riots, sabotages, impositions of sanctions, embargoes, nuclear, chemical or biological contaminations, laws or action taken by a government or public authority, quotas or prohibition, expropriations, destructions of the worksite, explosions, fires, accidents, any labour or trade disputes, strikes or lockouts

11. CONFIDENTIALITY

- 11.1. The documents and data provided to or prepared by the Society in performing the Services, and the information made available to the Society, are treated as confidential except where the information:
 - is already known by the receiving Party from another source and is properly and lawfully in the possession of the receiving Party prior to the date that it is disclosed;
 - is already in possession of the public or has entered the public domain, otherwise than through a breach of this obligation;
 - is acquired independently from a third party that has the right to disseminate such information;
 - is required to be disclosed under applicable law or by a governmental order, decree, regulation or rule or by a stock exchange authority (provided that the receiving Party shall make all reasonable efforts to give prompt written notice to the disclosing Party prior to such disclosure).

- 11.2. The Society and the Client shall use the confidential information exclusively within the framework of their activity underlying these Conditions.

- 11.3. Confidential information shall only be provided to third parties with the prior written consent of the other Party. However, such prior consent shall not be required when the Society provides the confidential information to a subsidiary.

- 11.4. The Society shall have the right to disclose the confidential information if required to do so under regulations of the International Association of Classifications Societies (IACS) or any statutory obligations.

12. INTELLECTUAL PROPERTY

- 12.1. Each Party exclusively owns all rights to its Intellectual Property created before or after the commencement date of the Conditions and whether or not associated with any contract between the Parties.
- 12.2. The Intellectual Property developed for the performance of the Services including, but not limited to drawings, calculations, and reports shall remain exclusive property of the Society.

13. ASSIGNMENT

- 13.1. The contract resulting from these Conditions cannot be assigned or transferred by any means by a Party to a third party without the prior written consent of the other Party.
- 13.2. The Society shall however have the right to assign or transfer by any means the said contract to a subsidiary of the Bureau Veritas Group.

14. SEVERABILITY

- 14.1. Invalidity of one or more provisions does not affect the remaining provisions.
- 14.2. Definitions herein take precedence over other definitions which may appear in other documents issued by the Society.
- 14.3. In case of doubt as to the interpretation of the Conditions, the English text shall prevail.

15. GOVERNING LAW AND DISPUTE RESOLUTION

- 15.1. The Conditions shall be construed and governed by the laws of England and Wales.
- 15.2. The Society and the Client shall make every effort to settle any dispute amicably and in good faith by way of negotiation within thirty (30) days from the date of receipt by either one of the Parties of a written notice of such a dispute.
- 15.3. Failing that, the dispute shall finally be settled by arbitration under the LCIA rules, which rules are deemed to be incorporated by reference into this clause. The number of arbitrators shall be three (3). The place of arbitration shall be London (UK).

16. PROFESSIONAL ETHICS

- 16.1. Each Party shall conduct all activities in compliance with all laws, statutes, rules, and regulations applicable to such Party including but not limited to: child labour, forced labour, collective bargaining, discrimination, abuse, working hours and minimum wages, anti-bribery, anti-corruption. Each of the Parties warrants that neither it, nor its affiliates, has made or will make, with respect to the matters provided for hereunder, any offer, payment, gift or authorization of the payment of any money directly or indirectly, to or for the use or benefit of any official or employee of the government, political party, official, or candidate.
- 16.2. In addition, the Client shall act consistently with the Society's Code of Ethics of Bureau Veritas. <http://www.bureauveritas.com/home/about-us/ethics+and+compliance/>

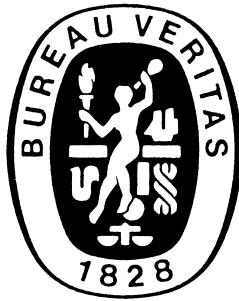

RULE NOTE NR 645

NR 645

Rules for the Classification of Floating Storage Regasification Units

SECTION 1	GENERAL PRINCIPLE OF CLASSIFICATION
SECTION 2	CLASSIFICATION OF FSRUs
SECTION 3	STABILITY AND SUBDIVISION
SECTION 4	HYDRODYNAMIC ANALYSIS
SECTION 5	DESIGN LOADS ON SITE
SECTION 6	STRUCTURE DESIGN PRINCIPLES
SECTION 7	STRUCTURE STRENGTH
SECTION 8	UNIT ARRANGEMENT
SECTION 9	CARGO CONTAINMENT
SECTION 10	REGASIFICATION PLANT (REGAS)
SECTION 11	ELECTRICAL INSTALLATIONS
SECTION 12	HAZARDOUS AREAS
SECTION 13	MACHINERY, AUTOMATION AND FIRE PROTECTION
SECTION 14	SURVEY AND INSPECTION

Section 1 General Principle of Classification

1	Purpose of the Rules	7
1.1	General	
2	Classification principles	7
2.1	General	
2.2	Purpose of the classification notations	
2.3	Types of notations assigned	
3	Class symbol	7
3.1	General	
4	Construction marks	8
4.1	General	
4.2	List of construction marks	
5	Service notations and corresponding additional service features	8
5.1	General	
6	Additional class notations	8
6.1	General	
7	Assignment of Class	8
7.1	General	
8	Site conditions and related operating procedures	8
8.1	Design Criteria Statement on-site	
8.2	Operating manual on-site	
9	Statutory requirements	9
9.1	General	

Section 2 Classification of FSRUs

1	General	10
1.1	Application	
1.2	Exclusion	
2	Classification	11
2.1	Classification notations	
2.2	Site and transit notation	
2.3	Navigation notation	
3	Symbols and definitions	13
3.1	General	
3.2	Definitions	
3.3	Reference co-ordinate system	
4	Unit with service notation FSRU	15
4.1	Classification and towing/transit	
5	Document to be submitted	15
5.1	General	

Section 3 Stability and Subdivision

1	General	16
	1.1 Application	
2	Stability	16
	2.1 Stability calculations	
	2.2 Standard loading conditions on-site	
3	Stability and subdivision for units with service notation FSRU	16
	3.1 General	
	3.2 Standard loading conditions	
	3.3 Stability calculations	
	3.4 Damage stability	
	3.5 General arrangement	

Section 4 Hydrodynamic Analysis

1	General	18
	1.1 Application	
2	Units with service notation Liquefied gas carrier - FSRU	18
	2.1 General	

Section 5 Design Loads on Site

1	General	19
	1.1 Principles	
	1.2 Definitions	
	1.3 Application criteria	
2	Still water loads	20
	2.1 Loading manual	
	2.2 Hull girder still water loads	
	2.3 Loading instrument	
3	Wave loads	20
	3.1 Towing/transit and site conditions	
	3.2 Design wave loads	
	3.3 Hull girder wave loads	
	3.4 Unit motions and accelerations	
	3.5 Relative wave elevation	
4	Load cases	21
	4.1 Towing/transit and site conditions	
	4.2 Load cases for structural analyses	
5	Sea pressures	21
	5.1 General	
	5.2 Towing/transit and site conditions	
	5.3 Still water pressure	
	5.4 Wave pressure	

6	Internal pressures	22
6.1	Towing/transit and site conditions	
6.2	Mass densities	
6.3	Calculations	

Section 6 Structure Design Principles

1	Structural principles	23
1.1	General	
1.2	Typical arrangement	
2	Materials for construction	23
2.1	General	
3	Welding and weld connections	23
3.1	General	
4	Mooring fittings and foundations	23
4.1	General	
5	Reinforcements in way of supporting structures for hull attachments	23
5.1	Local arrangement	
6	Access	23
6.1	Access manual	

Section 7 Structure Strength

1	Application	24
1.1	Units with the service notation liquefied gas carrier - FSRU	
1.2	Units with the service notation FSRU	
2	Hull girder strength on-site	24
2.1	Application	
2.2	Strength characteristics of the hull girder transverse sections	
2.3	Yielding checks	
2.4	Ultimate strength Check	
3	Hull Scantling on-site	24
3.1	General	
3.2	Plating	
3.3	Ordinary stiffeners	
3.4	Primary supporting members	
4	Fatigue check of structural details	25
4.1	General	
4.2	Structural details	
4.3	Units with service notation Liquefied gas carrier - FSRU	
4.4	Units with service notation FSRU	

Section 8 Unit Arrangement

1	General	26
1.1	Application	

Section 9 Cargo containment

1	General	27
1.1	Application	
2	Sloshing on-site	27
2.1	Partly filled tanks on-site	
3	Units with service notation Liquefied gas carrier - FSRU	27
3.1	Sloshing	

Section 10 Regasification Plant (REGAS)

1	General	28
1.1	Application	
1.2	Principal	
1.3	Documents to be submitted	
1.4	Identified risk and hazards	
1.5	Layout	
1.6	Structure	
1.7	Piping process safety features, mechanical integrity	
1.8	Monitoring and control	
1.9	Fire Safety features	
1.10	Certification scheme	
1.11	Tests after installation onboard	
1.12	References and codes	

Section 11 Electrical Installations

1	General	33
1.1	Application	
2	Hazardous locations and types of equipment	33
2.1	Electrical equipment permitted in gas-dangerous spaces and zones	
3	Units with service notation FSRU	33
3.1	General	
3.2	Supply systems	
3.3	Impedance earthed distribution system	
3.4	Distribution systems in hazardous areas	
3.5	High voltage installations	

Section 12 Hazardous Areas

1	General	35
	1.1 General	
	1.2 General requirements	
	1.3 Definitions	
2	Hazardous areas	35
	2.1 Classification of hazardous areas due to storage, off-loading and regasification plant	

Section 13 Machinery, Automation and Fire Protection

1	General	37
	1.1 Application	

Section 14 Survey And Inspection

1	General	38
	1.1 Application	
2	Bottom surveys	38
	2.1 General	
3	Tailshaft surveys	39
	3.1 General	
4	Mooring system	39
	4.1 General	
5	Design requirements for survey	39
	5.1 General	
	5.2 Cargo tanks inspection	
	5.3 Cargo handling equipment	

SECTION 1

GENERAL PRINCIPLE OF CLASSIFICATION

1 Purpose of the Rules

1.1 General

1.1.1 The requirements of this Rule Note apply specifically to Floating Storage Regasification Units (FSRUs) defined as floating units fitted with equipment for storage and regasification of liquefied natural gas (LNG) as defined in Sec 2, [1.1.1].

Note 1: This Rules note does not apply to:

- floating units designed for gas production for which reference is made to NR542
- pure gas carrier designed for LNG trading only or for bunkering operation for which reference is made to NR467 Rules for Steel Ships, Part D, Chapter 9 and NR620, respectively.

2 Classification principles

2.1 General

2.1.1 In general, principles of classification set out in Pt A, Ch 1, Sec 1 of the Ship Rules and Pt A, Ch 1, Sec 1 of the Offshore Rules apply.

Note 1: "Ship Rules" and "Offshore Rules" are defined in Sec 2, [3].

2.2 Purpose of the classification notations

2.2.1 The classification notations give the scope according to which the class of the unit has been based and refer to the specific rule requirements, which are to be complied with for their assignment. In particular, the classification notations are assigned according to the type, service and navigation of the unit and other criteria which have been provided by the Interested Party, when applying for classification.

The Society may change the classification notations at any time, when the information available shows that the requested or already assigned notations are not suitable for the intended service, navigation and any other criteria taken into account for classification.

Note 1: Reference should be made to Pt A, Ch 1, Sec 1, [1.3] of the Ship Rules on the limits of classification and its meaning.

2.2.2 The classification notations assigned to a unit are indicated on the Certificate of Classification, as well as in the Register published by the Society.

2.2.3 The classification notations applicable to existing units conform to the Rules of the Society in force at the date of assignment of class. However, the classification notations of existing units may be updated according to the current Rules, as far as applicable.

2.3 Types of notations assigned

2.3.1 The types of classification notations assigned to a unit are the following:

- a) class symbol
- b) construction marks
- c) service notations with additional service features, as applicable
- d) navigation notations (may be optional)
- e) site notation (may be optional)
- f) transit notation (may be optional)
- g) additional class notations (may be optional).

The different classification notations and their conditions of assignment are listed in [3], [4] [5] [6]and Sec 2, [2] according to their types.

3 Class symbol

3.1 General

3.1.1 The class symbol expresses the degree of compliance of the ship with the rule requirements as regards its construction and maintenance. There is one class symbol, which is compulsory for every classed unit.

3.1.2 The class symbol **I** is assigned to units built in accordance with the requirements of the Rules or other rules recognised as equivalent, and maintained in a condition considered satisfactory by the Society.

The period of class (or interval between class renewal surveys) assigned to class symbol **I** units is maximum 5 years, see Ch 2, Sec 2, [4] of the Ship Rules.

Note 1: The class symbol **I** is to be understood as being the highest class granted by the Society.

3.1.3 The class symbol **II** is assigned to units which do not meet all requirements for class symbol **I**, but are deemed acceptable to be entered into the Register of Ships.

The period of class assigned to class symbol **II** ships is maximum 3 years, see Ch 2, Sec 2, [4] of the Ship Rules.

3.1.4 Except for special cases, class is assigned to a unit only when the hull, propulsion and auxiliary machinery installations, and equipment providing essential services have all been reviewed in relation to the requirements of the Rules.

4 Construction marks

4.1 General

4.1.1 The construction mark identifies the procedure under which the unit and its main equipment or arrangements have been surveyed for initial assignment of the class. The procedures under which the ship is assigned one of the construction marks are detailed in Ch 2, Sec 1 of the Ship Rules.

4.1.2 One of the construction marks defined below is assigned separately to the hull of the unit and its appendages, to the machinery installation, and to some installations for which an additional classification notation (see Sec 2, [2]) is assigned.

The construction mark is placed before the symbol **HULL** for the hull, before the symbol **MACH** for the machinery installations, and before the additional class notation granted, when such a notation is eligible for a construction mark.

If the unit has no machinery installations covered by classification, the symbol **MACH** is not granted and the construction mark will be only placed before the symbol **HULL**.

4.1.3 The construction marks refer to the original condition of the unit. However, the Society may change the construction mark where the unit is subjected to repairs, conversion or alterations.

4.2 List of construction marks

4.2.1 The mark \boxtimes is assigned to the relevant part of the unit, when it has been surveyed by the Society during its construction in compliance with the new building procedure detailed in Ch 2, Sec 1, [2.1] of the Ship Rules, or when it is changing class from an IACS Society at ship's delivery or when class is being added to an IACS Society's class at unit's delivery in accordance with specific procedures.

4.2.2 The mark \boxplus is assigned to the relevant part of the ship, when the latter is classed after construction in compliance with the procedure detailed in Ch 2, Sec 1, [3.2] of the Ship Rules and it is changing class from an IACS Society at the time of the admission to class.

4.2.3 The mark \bullet is assigned to the relevant part of the unit, where the procedure for the assignment of classification is other than those detailed in [4.2.1] and [4.2.2], but however deemed acceptable.

5 Service notations and corresponding additional service features

5.1 General

5.1.1 The service notations define the type and/or service of the unit which have been considered for its classification, according to the request for classification signed by the Interested Party. At least one service notation is to be assigned to every classed unit.

Note 1: The service notations applicable to existing units conform to the Rules of the Society in force at the date of assignment of class. However, the service notations of existing units may be updated according to the current Rules, as far as applicable, at the request of the Interested Party.

A service notation may be completed by one or more additional service features, giving further precision regarding the type of service of the unit, for which specific rule requirements are applied.

The different service notations which may be assigned to a unit and the different additional service features are listed in Sec 2, [2].

6 Additional class notations

6.1 General

6.1.1 An additional class notation expresses the classification of additional equipment or specific arrangement, which has been requested by the Interested Party.

The assignment of such an additional class notation is subject to the compliance with additional rule requirements, which are detailed in Part A of the Ship Rules or Part A of the Offshore Rules.

Some additional class notations are assigned a construction mark, according to the principles given in [4.1.2]. This is indicated in the definition of the relevant additional class notations.

The different additional class notations which may be assigned to a unit are listed in Sec 2, [2].

7 Assignment of Class

7.1 General

7.1.1 In general, assignment of class set out in Pt A, Ch 2, Sec 1 of the Ship Rules or Pt A, Ch 1, Sec 3 of the Offshore Rules applies.

8 Site conditions and related operating procedures

8.1 Design Criteria Statement on-site

8.1.1 General

Classification is based upon the design data or assumptions specified by the party applying for classification.

A Design Criteria Statement is to list the service(s) performed by the unit and the design conditions and other assumptions on the basis of which class is assigned to the unit.

The Design Criteria Statement is issued by the Society, based on information provided by the party applying for classification.

The Design Criteria Statement is to be referred to in a Memorandum on the class certificate.

The Design Criteria Statement is to be incorporated in the Operating Manual as prescribed in [8.2].

8.1.2 Unit's activities

The Design Criteria Statement is to list the main services for which the unit is designed, the service notation and other notations assigned to the unit.

The nature of the unit's activity is to be duly accounted for in the application of the present Rules, as far as classification is concerned.

The Design Criteria Statement is to mention when the unit is a permanent unit, and to make reference to the applicable site data.

8.1.3 Structural design criteria

The Design Criteria Statement is to list the necessary data pertaining to the structural design of the unit for the different conditions of operation on-site of the unit, according to provisions of Pt B, Ch 2 of the Offshore Rules, if relevant.

Note 1: Transit of non self-propelled units is covered by classification as regards only the unit's structural overall and local strength as well as stability. All other aspects relating to towing are reviewed only on special request for a towage survey.

Note 2: As regards design of the foundations of equipment, classification is based upon the data submitted by the party applying for classification, under the format called for by the Rules.

8.1.4 Machinery, electrical and other system design conditions

The Party applying for classification is to submit the necessary description, diagrammatic plans, design data of all systems, including those used solely for the service performed by the unit on-site and, where applicable, their cross connections with other systems. The submitted data are to incorporate all information necessary to the assessment of the unit for the purpose of the assignment of class or for the assignment of additional class notations.

In accordance with [8.1.1] the party applying for classification is to give an estimation of electric balance for the different conditions of operation on-site of the unit. The specifications are to list all important equipment and apparatus, their rating and the power factors as applicable.

8.2 Operating manual on-site

8.2.1 An Operating Manual, which includes instructions regarding the safe operation of the unit and of the systems and equipment fitted on the unit, is to be placed onboard the unit.

The Operating Manual is to incorporate a dedicated section containing all information relating to classification, particularly environmental, loading and other design criteria as well as classification restrictions. The Operating Manual is to be, at all times, placed on board the unit and made available to all concerned. A copy of the Operating Manual is to be retained ashore by the Owners of the unit or their representatives.

It is the responsibility of the Interested Party to prepare the contents of the Operating Manual.

9 Statutory requirements

9.1 General

9.1.1 Project specification

Prior to commencement of the review of drawings, the complete list of Regulations, Codes and Statutory Requirements to be complied with is to be submitted for information:

- International Regulations
- Flag State requirements
- Coastal State requirements.

The project specification is also to specify the list of statutory certificates requested by the Owner.

9.1.2 Conflict of Rules

In case of conflict between the present Rules and any Statutory Requirements as given by Flag State or Coastal State, most stringent requirements are to be applied.

SECTION 2

CLASSIFICATION OF FSRUs

1 General

1.1 Application

1.1.1 FSRUs (as defined in Sec 1, [1.1.1]) complying with this Rule Note are assigned one of the notation **liquefied gas carrier - FSRU** or **FSRU** as defined in [2.1.1].

1.1.2 Units intended to be assigned with the service notation **liquefied gas carrier - FSRU** or **FSRU**, as defined in [2.1.1], are to comply with the requirements of IGC Code, except where otherwise specified in this Rule Note. This

Rule Note provides additional requirements and interpretations of IGC Code to be considered for the purpose of classification. The Society may refer to IGC Code, as defined in [3.2.3], when deemed necessary.

1.1.3 In general, units with the service notation **liquefied gas carrier - FSRU** are to comply with the requirements indicated in Tab 1.

1.1.4 In general, units with the service notation **FSRU** are to comply with the requirements indicated in Tab 1, as relevant, unless where indicated otherwise in this Rule Note.

Table 1 : Applicable requirements

Item	Service notations liquefied gas carrier - FSRU	Service notations FSRU
General arrangement	Sec 8 NR467, Part B NR467, Pt D, Ch 9	Sec 8 (1) NR467, Part B (1) NR467, Pt D, Ch 9 (1)
Hull and cargo containment	Sec 3 (1) Sec 4 (1) Sec 5 Sec 6 (1) Sec 8 NR467, Part B NR467, Pt D, Ch 9	Sec 3 Sec 4 Sec 5 Sec 6 Sec 8 NR467, Part B (1) NR467, Pt D, Ch 9 (1)
Materials and welding	Sec 6 NR467, Pt D, Ch 9 NR216	Sec 6 NR467, Pt D, Ch 9 NR216
Stability	Sec 3 NR467, Part B NR467, Pt D, Ch 9	Sec 3 NR467, Part B (1) NR467, Pt D, Ch 9 (1)
Machinery, cargo systems and safety features	Sec 10 Sec 12 Sec 13 NR467, Part C NR467, Pt D, Ch 9	Sec 10 Sec 12 (1) Sec 13 NR467, Part C (1) NR467, Pt D, Ch 9 (1)
Electrical installations and automation	Sec 11 Sec 12 NR467, Part C NR467, Pt D, Ch 9	Sec 11 Sec 12 NR467, Part C (1) NR467, Pt D, Ch 9 (1)
Survey and inspection	Sec 14	Sec 14
(1) When relevant		
Note 1: NR467: Rules for the Classification of Steel Ships (Ship Rules) NR216: Rules on Materials and Welding for the Classification of Marine Units (Materials & Welding).		

Table 2 : Typical classification notations for unit with the service notation liquefied gas carrier - FSRU

Classification notations		Reference
Class symbol	I or II	Sec 1, [3]
Construction mark	⊕, ⊗ or • to be separately assigned before: - HULL notation - MACH notation	Sec 1, [4]
Service notations	liquefied gas carrier - FSRU	[2.1.1]
Additional service features	POSA or POSA jetty SLOSHING	[2.1.2]
Navigation notation	unrestricted navigation summer zone tropical zone coastal area sheltered area	[2.3]
Additional class notations	INWATERSURVEY	NR467, Pt A, Ch 1, Sec 2
	MON-SHAFT	NR467, Pt A, Ch 1, Sec 2
	REGAS	[2.1.2]
	Veristar Hull CM FAT xx years (FEM and fatigue analysis of ship's hull structure (xx years) and Construction monitoring) (1) (2)	NR467, Pt A, Ch 1, Sec 2
	AUT-UMS (automation) (2) AUT-PORT (automation) (2)	NR467, Pt A, Ch 1, Sec 2
	IATP (Increased allowable tank design pressure)	NR467, Pt A, Ch 1, Sec 2
	ALM (lifting appliances) (2)	NR467, Pt A, Ch 1, Sec 2
	liquefied gas offloading (LNG transfer system) (2)	NR542
	ERS-S (Emergency response service) (2)	NR467, Pt A, Ch 1, Sec 2
	CLEANSHIP (prevention of pollution) (2)	NR467, Pt A, Ch 1, Sec 2
	CPS (WBT) (coating performance standard) (2)	NR467, Pt A, Ch 1, Sec 2
	GREEN PASSPORT (unit recycling) (2)	NR467, Pt A, Ch 1, Sec 2
STAR-REGAS (maintenance plan of regasification installation) (2)	NR467, Pt A, Ch 1, Sec 2	
(1) With $25 \leq xx \leq 40$		
(2) Optional		

1.2 Exclusion

1.2.1 This Rule note does not cover the emergency escape mode due to harsh weather or accidental cases (for instance fire, explosion). This emergency escape mode is considered beyond the scope of classification, unless specific demand has been received from the party applying for classification.

Note 1: Emergency escape mode correspond to the possibility for the unit to leave the jetty and navigate at low speed for a short voyage during an emergency.

2 Classification

2.1 Classification notations

2.1.1 Service notations

Units complying with this Rule Note are assigned with one of the following notations:

- **liquefied gas carrier - FSRU**, when the floating unit is designed to operate as a regasification unit with the possibility of trading LNG in a navigation mode
- **FSRU**, when the floating unit is designed to operate as a regasification unit permanently moored without trading LNG.

2.1.2 Additional service features

The following additional service features defined in Pt A, Ch 1, Sec 2 of the Offshore Rules may be assigned to units covered by the present Rule Note when relevant:

- **SLOSHING** - mandatory for units with service notation **liquefied gas carrier - FSRU** or **FSRU** using membrane tanks for cargo containment.

Note 1: **SLOSHING** may also be requested by the Society on a case-by-case basis for containment systems other than membrane type, if deemed necessary considering the specific design of the containment system.

- for units with service notation **FSRU**, one of the additional service features **POSA** or **POSA JETTY** is mandatory for permanent installations, as defined in [3.2.4]
- for units, with service notation **liquefied gas carrier - FSRU** considered as permanent installations, as defined in [3.2.4]:
 - Moored at a jetty: **POSA JETTY** - recommended
 - Moored at sea: **POSA** - mandatory.

2.1.3 Additional Class notations

The following additional class notations are mandatory for units covered by the present Rule Note:

- **REGAS**, as defined in Sec 10

- **INWATERSURVEY**, as defined in Pt A, Ch 1, Sec 2, [6.4.13] of the Ship Rules
- **MON-SHAFT**, as defined in Pt A, Ch 1, Sec 2 [6.6.3] of the Ship Rules, if relevant.

2.1.4 Typical classification notations

As an example, the typical classification notations assigned to a unit with the service notation **FSRU** is given in Tab 3 and the typical classification notations assigned to a unit with the service notation **liquefied gas carrier - FSRU** is given in Tab 2.

Note 1: The kind of notation shown in brackets does not form part of the classification notation indicated in the Register of Ships and on the Certificate of Classification.

Table 3 : Typical classification notations for unit with the service notation FSRU

Classification notations		Reference
Class symbol	I or II	Sec 1, [3]
Construction mark	☒, ☒ or • to be separately assigned before: - HULL notation - MACH notation	Sec 1, [4]
Service notations	FSRU	[2.1.1]
Additional service features	POSA or POSA jetty SLOSHING	[2.1.2]
Site notation	- name of site - geographical area of operation - most unfavorable sea conditions	[2.2]
Transit notation	transit - specific criteria (2)	[2.2]
Additional class notations	INWATERSURVEY	NR467, Pt A, Ch 1, Sec 2
	MON-SHAFT (3)	NR467, Pt A, Ch 1, Sec 2
	REGAS	[2.1.2]
	Veristar Hull CM FAT xx years (FEM and fatigue analysis of ship's hull structure (xx years) and Construction monitoring) (1) (2)	NR467, Pt A, Ch 1, Sec 2
	AUTO (automation) (2)	NR445, Pt A, Ch 1, Sec 2
	IATP (Increased allowable tank design pressure) (2)	NR467, Pt A, Ch 1, Sec 2
	ALM (lifting appliances) (2)	NR467, Pt A, Ch 1, Sec 2
	liquefied gas offloading (LNG transfer system) (2)	NR542
	LSA (Life saving appliances) (2)	NR445, Pt A, Ch 1, Sec 2
	ERS-S (Emergency response service) (2)	NR467, Pt A, Ch 1, Sec 2
	CLEANSHIP (prevention of pollution) (2)	NR467, Pt A, Ch 1, Sec 2
	CPS (WBT) (coating performance standard) (2)	NR467, Pt A, Ch 1, Sec 2
	GREEN PASSPORT (unit recycling) (2)	NR467, Pt A, Ch 1, Sec 2
	OHS (handling systems and associated equipment) (2)	NR595
STAR-REGAS (maintenance plan of regasification installation) (2)	NR467, Pt A, Ch 1, Sec 2	
(1) With $25 \leq xx \leq 40$ (2) Optional (3) When relevant		

2.2 Site and transit notation

2.2.1 Site notation

Units with the service notation **FSRU** are to be granted with a site notation, consisting in the name of field and/or geographical area and/or the most unfavorable sea conditions where the unit is intended to operate.

For units with the notation **liquefied gas carrier - FSRU**, the site notation is not mandatory.

In both cases, the data, limitations and assumptions used for the assessment of the unit on site are stated in the Design Criteria Statement, as defined in Sec 1, [8.1], which is referred on a memorandum on the class certificate.

2.2.2 Transit notation

Units with the service notation **FSRU** involved in towing or transit by means of its own propulsion system between construction shipyard and the intended site, or between different operation sites, are to be granted with the notation **transit**.

The notation transit is to be completed as follows:

- **transit - specific criteria**, when the criteria for the assessment in towing/transit phase are based on data and assumptions specified by the party applying for classification. These criteria are to be stated in the Design Criteria Statement, as defined in Sec 1, [8.1], which is referred to on a memorandum on the class certificate
- for unit with the service notation **FSRU**, the notation **transit** may be completed by one of the navigation notation given in [2.3].

Example: **transit - unrestricted navigation**.

Units with the notation **liquefied gas carrier - FSRU**, need not be assigned with a **transit** notation.

2.3 Navigation notation

2.3.1 Units with the service notation **liquefied gas carrier - FSRU** are to be assigned one of the followings navigation notation:

- the navigation notation **unrestricted navigation** is assigned to units intended to operate in any area and any period of the year
- the navigation notation **summer zone** is assigned to units intended to operate only within the geographical limits as defined in ILLC 1966 for the Summer zones
- the navigation notation **tropical zone** is assigned to units intended to operate only within the geographical limits as defined in ILLC 1966 for the Tropical zones
- the navigation notation **coastal area** is assigned to units intended to operate only within 20 nautical miles from the shore and with a maximum sailing time of six hours from a port of refuge or safe sheltered anchorage
- the navigation notation **sheltered area** is assigned to units intended to operate in sheltered waters, i.e. harbours, estuaries, roadsteads, bays, lagoons and generally calm stretches of water and when the wind force does not exceed 6 Beaufort scale.

2.3.2 Navigation notations listed in [2.3.1] may complete the site notation and/or transit notation of the unit, as described in [2.2].

2.3.3 The assignment of a navigation notation, including the reduction of scantlings or specific arrangements for restricted navigation notations, is subject to compliance with the requirements laid down in Part B, Part C, and Part D of the Ship Rules.

2.3.4 The assignment of a navigation notation does not absolve the Interested Party from compliance with any international and national regulations established by the Administrations for a unit operating in national waters, or a specific area, or a navigation zone. Neither does it waive the requirements in Pt A, Ch 1, Sec 1, [3.3.1] of the Ship Rules.

3 Symbols and definitions

3.1 General

3.1.1 Unless otherwise specified in [3.2] the units, symbols, definitions and reference co-ordinate system given in Pt B, Ch 1, Sec 2 of the Ship Rules remain applicable.

3.2 Definitions

3.2.1 Ship Rules

Ship Rules means Bureau Veritas Rules for the Classification of Steel Ships (NR467). When reference is made to the Ship Rules, the latest version of these ones is applicable.

3.2.2 Offshore Rules

Offshore Rules means Bureau Veritas Rules for the Classification of Offshore Units (NR445). When reference is made to the Offshore Rules, the latest version of these ones is applicable.

3.2.3 IGC Code

IGC Code means the International Code for the Construction and Equipment of Ships Carrying Liquefied Gases in Bulk, as amended.

Where requirements of IGC Code are quoted as excerpts, they are printed in italic type.

3.2.4 Permanent installation

Units are considered as permanent installations when performing their service either:

- at a single location, or
- on a single site for a duration not less than, typically, 5 years.

Two types of permanent installations are to be considered:

- disconnectable, when the unit has a means of disengaging from its mooring and riser systems in extreme environmental or emergency conditions
- non-disconnectable.

A permanent installation is assigned with a site notation consisting in the name of the unit operation field.

3.2.5 Site draughts

The draught is the distance, in m, from the base line to the waterline, measured amidships.

The maximum site draught T_{\max} is the deepest draught able to be observed during operation.

The minimum site draught T_{\min} is the lightest draught able to be observed during operation.

3.2.6 Rule length L

For a unit with propulsion system, the rule length L is determined similarly to seagoing ships (see the Ship Rules, Pt B, Ch 1, Sec2). In case of units without rudder shaft, the rule length L is to be taken equal to 97% of the extreme length at the maximum draught.

The extreme length at the maximum draught is not to include external turret system or boat landing platforms possibly attached to the extreme ends.

3.2.7 Transit draughts

For any transit phase, a maximum draught and a minimum draught are to be determined by the designer, and reflected in the associated loading conditions.

3.2.8 Navigation condition

The navigation condition represents, for units assigned with the notation liquefied gas carrier-FSRU, the operation phase under sailing conditions and the associated loads taking into account the assigned navigation notation.

3.2.9 Site condition

For both notations (**liquefied gas carrier - FSRU** and **FSRU**), the site condition represents the operation phase under regasification mode on site and the associated loads taking into account the assigned site notation.

3.2.10 Fore and aft parts

For units with the service notation **FSRU**, the fore part and aft part are determined on a case-by-case basis, according to the main wave heading.

For units articulated around a single point mooring, the fore part is the part next to this single point mooring.

During transit, the fore part is the one orientated in the direction of towage.

3.2.11 Hull and superstructures

The hull is a floating structure with overall dimensions in accordance with Pt B, Ch 5, Sec 2 of the Ship Rules. The purpose is to store cargo, ballast and production liquids. In addition, there are dedicated machinery spaces provided for essential generators, etc.

The definition of the hull includes the living quarters, which are to be designed and built in accordance with the relevant requirements for superstructures, as given by the Ship Rules.

3.2.12 Regasification area

Regasification area includes:

- regasification skid
- process equipment for regasification
- foundations for the support of regasification skid.

3.2.13 Cargo

Cargo means liquefied gas stored and processed by units subject to the present Rule. The list of products to be considered as cargo is given in Pt D, Ch 9, Sec 19 of the Ship Rules.

3.2.14 Cargo containment system

Cargo containment system is the arrangement for containment of cargo, including, where fitted, a primary and secondary barrier, associated insulation and any intervening spaces, and adjacent structure if necessary for the support of these elements. If the secondary barrier is part of the hull structure, it may be a boundary of the hold space.

3.2.15 Primary barrier

Primary barrier is the inner element designed to contain the cargo when the cargo containment system includes two boundaries.

3.2.16 Secondary barrier

Secondary barrier is the liquid resistant outer element of a cargo containment system designed to afford temporary containment of any envisaged leakage of liquid cargo through the primary barrier and to prevent the lowering of the temperature of the unit's structure to an unsafe level.

3.2.17 Integral tank

Integral tanks form a structural part of the unit's hull and are influenced in the same manner and by the same loads which stress the adjacent hull structure. Integral tanks may be used for cargoes having a boiling point not below -10°C .

3.2.18 Independent tank

Independent tanks are self-supporting tanks; they do not form part of the unit's hull and are not essential to the hull strength. There are three types of independent tanks:

- type A
- type B
- type C,

as defined in IGC Code.

3.2.19 Membrane tanks

Membrane tanks are non-self-supporting tanks which consist of a thin layer (membrane) supported through insulation by the adjacent hull structure. The membrane is designed in such a way that the thermal and other expansion or contraction is compensated for without undue stressing of the membrane.

3.3 Reference co-ordinate system

3.3.1 The unit's geometry, motions, accelerations and loads are defined with respect to the following right-hand co-ordinate system (see Fig 1):

- Origin : At the intersection between the longitudinal plane of symmetry of the unit, the aft end of L and the baseline
- X axis : Longitudinal axis, positive forwards
- Y axis : Transverse axis, positive towards portside
- Z axis : Vertical axis, positive upwards.

Positive rotations are oriented in anti-clockwise direction about the X, Y and Z axes.

Figure 1 : Reference co-ordinate system

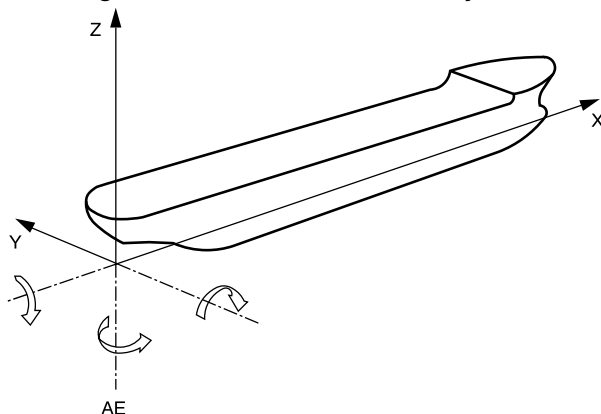

4 Unit with service notation FSRU

4.1 Classification and towing/transit

4.1.1 The towing or transit by means of own propulsion system, between the construction shipyard and the intended site, is covered by classification requirements.

To flag the unit is:

- recommended for the towing
- mandatory in international waters and when people is onboard. Attention is to be paid to the compliance with international codes and standards as required by National Authorities.

The Society issues a provisional certificate upon completion of the hull, with design criteria for towing/transit condition clearly identified.

4.1.2 Temporary conditions

In accordance with the provisions of classification, any temporary conditions during fabrication and load out, any intermediate towing between two construction sites before complete finalisation of the unit and final load out of top-side modules are considered beyond the scope of classification, unless a specific demand has been received from the party applying for classification.

Corrosion protection systems are to be arranged for the hull during the outfitting phase. The documentation is to be submitted to the Society for information. The Society may require thickness measurements to be carried out prior to the hull leaving the yard.

4.1.3 Environmental conditions for towing/transit

The Society may require:

- detailed documentation for the intended route between the construction shipyard and the intended site, and
- further investigation of slamming loads, green waters, bow impact and ice loads, if any, depending on the severity of the intended route, the planned period of the year and duration for the towing.

Extreme loads for towing/transit are to be taken by default for a return period of 10 years (typically referred to as a probability level of 10^{-7}). Different values may be considered if specified by the party applying for classification.

Limitations on sea heading (for avoidance of beam seas) including possible seasonal limitations are to be defined by the Owner and/or the party applying for classification.

4.1.4 Fatigue strength during towing/transit

The Society reserves the right to require, for structural members, a direct fatigue analysis resulting from the towing/transit. Such fatigue analysis is to be combined with the overall fatigue verification of the unit in operation at intended site.

4.1.5 Temporary mooring during towing/transit

The unit is to be equipped with temporary mooring (anchoring) equipment during the towing/transit operation. This equipment may be removed when the unit is permanently moored at the operation site.

5 Document to be submitted

5.1 General

5.1.1 The documentation to be submitted is to include the following information, in addition to the documentation required in Part D, Ch 9 of the Ship Rules and required in the other sections of this Rule Note:

- a) design criteria and data, as defined in Sec 1, [8.1]
- b) data for hydrodynamic analysis:
 - lines plan and appendices on hull
 - environmental data as required in Pt B, Ch 2, Sec 2 of the Offshore Rules
 - properties of the unit related to the assessment of wind and current loads (areas, coefficients), when a heading analysis is performed (see Sec 4)
 - properties of mooring system and relevant information
 - loading manual with description of each loading condition.
- c) others:
 - documents relevant to the contemplated additional class notations.

SECTION 3

STABILITY AND SUBDIVISION

1 General

1.1 Application

1.1.1 The requirements related to stability and subdivision specified in Pt D, Ch 9, Sec 2 and Part B of the Ship Rules are applicable, except where specifically indicated otherwise in this Section.

2 Stability

2.1 Stability calculations

2.1.1 Free surface effects

The free surface effects of partially filled tanks are to be taken into account in the stability calculations. Filling restrictions entered in the operating manual are to be given special consideration by the Society.

Free surface effects are to be considered whenever the filling level in a tank is less than 98% of full condition. Free surface effects need not be considered where a tank is nominally full, i.e. filling level is 98% or above.

Nominally full cargo tanks are to be corrected for free surface effects at 98% filling level. In doing so, the correction to initial metacentric height should be based on the inertia moment of liquid surface at 5° of the heeling angle divided by displacement, and the correction to righting lever is suggested to be on the basis of real shifting moment of cargo liquids.

In calculating the free surfaces effect in tanks containing consumable liquids, it is to be assumed that for each type of liquid at least one transverse pair or a single centreline tank has a free surface and the tank or combination of tanks taken into account are to be those where the effect of free surface is the greatest.

2.2 Standard loading conditions on-site

2.2.1 Standard loading conditions on-site

The following standard loading conditions are to be included in the trim and stability booklet:

- lightweight condition
- normal operation conditions with maximum deck loads and equipment in the most unfavourable positions, if relevant
- inspection conditions consistent with the operational procedures

- loading condition for inspection of cargo tanks, where one cargo tank or two consecutive cargo tanks is/are empty (to be considered in accordance with operational procedures)
- selected operational conditions covering foreseen fillings of cargo tanks. One of the conditions is to correspond to the maximum draught. The selection is to include loading and off-loading conditions

For the assignment of a tropical freeboard, the corresponding loading condition is also to be submitted.

3 Stability and subdivision for units with service notation FSRU

3.1 General

3.1.1 Application

For units with service notation **FSRU**, additional requirements and relaxation are given in this Article.

3.2 Standard loading conditions

3.2.1 Standard loading conditions

The following standard loading conditions are to be included in the trim and stability booklet, in addition to the loading conditions defined in [2.2]:

- transit/towing condition, if relevant
- severe storm conditions assuming the same weight distribution as for transit/towing, as relevant, except for the ballast adjustments necessary to bring the unit to the survival draught and for the possible dumping of variable deck load, if specified in the operational procedures
- severe storm conditions assuming the same weight distribution as for normal operation conditions with the ballast adjustments necessary to place the unit in the survival draught configuration. In these conditions:
 - equipment liable to be disconnected, such as single point mooring systems, is assumed disconnected
 - equipment liable to be disconnected and stored on deck is assumed disconnected and secured on deck
 - equipment having a rest position, such as crane booms, is assumed in rest position.

The maximum amount of loads is assumed to be stored on deck. Account may be taken of dumping of variable deck loads if specified in the operational procedures.

3.3 Stability calculations

3.3.1 Ice and snow conditions

For units with the service notation **FSRU** and liable to operate in areas of snow and glazed frost, the verification of the intact and damage stability is to be performed, taking into account the possible overloads due to ice and snow accumulation.

The requirements stipulated in Pt B, Ch 1, Sec 2, [2] of the Offshore Rules are to be complied with.

3.4 Damage stability

3.4.1 Extent of damage

The extent of damage on the bottom need not to be considered.

The assumed maximum extent of damage on the side shell is to be as follows:

- longitudinal extent ℓ_c :
 $\ell_c = 1/3 L_{LL}^{2/3}$ or 14,5 m whichever is the lesser
- transverse extent t_c measured inboard from the side shell plating, at right angle to the centreline, at the level of summer load line:
 $t_c = B/5$ or 11,5 m whichever is the lesser
- vertical extent v_c , from the moulded line of the bottom shell plating at centreline: upwards without limits.

If any damage of a lesser extent than the maximum damage specified above would result in a more severe condition, such damage is to be considered.

Local side damage anywhere in the extending inboard distance "d" as defined in Pt D, Ch 9, Sec 2, [4.1.1] of the Ship Rules, measured normal to the moulded line of the outer shell is to be considered. Bulkheads are to be assumed damaged when the relevant paragraph of [3.4.2] apply. If a damage of a lesser extent "d" would result in a more severe condition, such damage is to be considered.

3.4.2 Standard of damage

Units covered by this Rule Note are to sustain the damage indicated in [3.4.1] to the extent determined by the unit's type according to the following standards:

- a) a type 1G should be assumed to sustain damage anywhere in its length

- b) a type 2G of more than 150 m in length should be assumed to sustain damage anywhere in its length
- c) a type 2G of 150 m in length or less should be assumed to sustain damage anywhere in its length except involving either of the bulkheads bounding a machinery space located aft
- d) a type 2PG should be assumed to sustain damage anywhere in its length except involving transverse bulkheads spaced further apart than the longitudinal extent of damage as specified in [3.4.1].

Note 1: Definition of unit's type are given in Pt D, Ch 9, sec 2 [1.1.2] of the Ship Rules.

3.5 General arrangement

3.5.1 Cargo tanks location

Cargo tanks of units intended to receive the service notation **FSRU** are to be located as required in Pt D, Ch 9, Sec 2, [4] of the Ship Rules, taking into account the extent of damage defined in [3.4.1].

3.5.2 Collision bulkhead

A collision bulkhead is to be provided to prevent flooding during transit and/or site conditions.

The collision bulkhead is to comply with Pt B, Ch 2 of the Ship rules.

Subject to the agreement of the flag Administration, if any, the Society may accept an exemption from having a collision bulkhead when the risk of collision is mitigated and duly justified (collision analysis, external turret, damage stability...).

Subject to the agreement of the flag Administration, if any, the Society may, on a case by case basis, accept a distance from the collision bulkhead to the forward perpendicular FPLL greater than the maximum specified in the Ship rules, provided that subdivision and stability calculations show that, when the unit is in upright condition on full load draft, flooding of the space forward of the collision bulkhead will not result in any part of the freeboard deck becoming submerged, or in any unacceptable loss of stability.

3.5.3 Aft peak bulkhead

As a rule, units are to be provided with an aft peak bulkhead in accordance with the Ship rules, except when the risk of collision is mitigated and duly justified (collision analysis, external turret, damage stability...).

SECTION 4

HYDRODYNAMIC ANALYSIS

1 General

1.1 Application

1.1.1 Hydrodynamic analysis is to be performed for both site conditions and towing/transit phases in accordance with the requirements of Pt D, Ch 1, Sec 4 of the Offshore Rule.

2 Units with service notation Liquefied gas carrier - FSRU

2.1 General

2.1.1 Hydrodynamic analysis is not mandatory for unit granted with the service notation **Liquefied gas carrier - FSRU**, except if the site condition is more severe than the condition given by the navigation condition, but justification is to be provided to the Society.

When the navigation condition covers the site condition, Sec 5 and Sec 7 are not applicable except the requirements Sec 7, [1.1.1] and Sec 7, [4.3].

SECTION 5

DESIGN LOADS ON SITE

1 General

1.1 Principles

1.1.1 Application

The design loads on site are to be determined in accordance with this Section and are to consider the relevant loading conditions and associated loads including:

- still water conditions
- extreme environmental conditions during unit's operation (100 years return period)
- loading and off-loading conditions, taking into account side-by-side or tandem configuration, as relevant
- limiting conditions before the disconnection from single point mooring, if relevant
- conditions during maintenance or inspection operations
- transit/towing conditions, from the construction/conversion location to offshore site and between constructing shipyards, if more than one
- loads induced by process and other equipment, in above conditions, as relevant
- damaged conditions, taking into account the provisions and damage assumptions as given in Sec 3.

In case of units with the service notation **Liquefied Gas Carrier - FSRU** and if the site condition is less severe than the navigation condition, it is not necessary to apply this Section.

1.1.2 Site conditions

The design loads for site conditions are to be determined as stated in this Section, taking into account the results of hydrodynamic analysis (see Sec 4). Two situations may be considered:

- when a navigation notation completes the site notation of the unit, the rule values of wave loads for this navigation notation are to be superimposed with the values obtained from hydrodynamic analysis as defined in Sec 4
- when no navigation notation is granted to the unit for on-site conditions, the wave loads obtained from hydrodynamic analysis are to be superimposed with the rule values calculated for sheltered area, as defined in Article [3].

1.1.3 Towing/transit conditions

The design loads for towing/transit conditions are to be determined as stated in this Section, taking into account the results of hydrodynamic analysis. Two situations may be considered:

- when a navigation notation completes the transit notation of the unit, the rule values of wave loads for this navigation notation are to be superimposed with the values obtained from hydrodynamic analysis, as defined in [3.2]

- when no navigation notation is granted to the unit for towing/transit conditions, the wave loads obtained from hydrodynamic analysis are to be used, as defined in [3.2].

1.2 Definitions

1.2.1 The definition of the following terms are given in Pt B, Ch 5, Sec 1, [1] of the Ship Rules:

- still water loads
- wave loads
- dynamic loads
- local loads
- hull girder loads
- loading condition
- load cases.

1.3 Application criteria

1.3.1 Hull girder loads

The wave and dynamic hull girder loads are to be used for the determination of:

- the hull girder strength, according to the requirements of Sec 7
- the structural scantling of platings, ordinary stiffeners and primary supporting members contributing to the hull girder strength, in combination with the local loads given in Articles [5] and [6], according to the requirements of Sec 7.

1.3.2 Load cases

The local loads defined in Articles [5] and [6] for the towing/transit and site conditions are to be calculated in each of the mutually exclusive load cases described in Article [4].

1.3.3 Unit motions and global accelerations

The wave local loads are to be calculated on the basis of the reference values of unit motions and global accelerations specified in [3.4].

1.3.4 Calculation and application of local loads

The criteria for the calculation of:

- still water local loads
- wave local loads on the basis of the reference values of unit motions and global accelerations

are specified in Articles [5] and [6].

1.3.5 Flooding conditions

The still water and wave pressures in flooding conditions are specified in [6.3.5].

1.3.6 Accidental loading cases

Following the HAZID & HAZOP outcomes results, the design of the floating unit is to consider the possibility of accidental loads as may result from collisions, dropped objects, fire or explosions (see Pt B, Ch 2, Sec 1, [4.3] of the Offshore Rules).

Accidental loading cases are required for the towing/transit and site phases.

In accidental conditions, environmental loads are to be evaluated taking into account the circumstances in which the considered situation may realistically occur, and the time needed for evacuation or other remedial action. The return period of such environmental loads is generally taken as 1 year.

1.3.7 Load definition criteria to be adopted in structural analyses of plates and secondary stiffeners

a) Application

This requirement applies for the definition of local loads to be used in the scantling checks of plating and ordinary stiffeners according to Sec 7.

b) Load model

1) when calculating the local loads for the structural scantling of an element which separates two adjacent compartments, the latter may not be considered simultaneously loaded. The local loads to be used are those obtained considering the two compartments individually loaded.

2) for elements of the outer shell, the local loads are to be calculated considering separately:

- the still water and wave external sea pressures, considered as acting alone without any counteraction from the unit internal compartments. This calculation is to be done considering the maximum draught
- the still water and wave differential pressures (internal minus external sea pressures) considering the compartment adjacent to the outer shell as being loaded. This calculation is to be made considering the minimum draught T_{mini} defined in Sec 2, [3.2.5].

Note 1: The external wave pressure in case "b" is to be taken equal to 0.

In the absence of more precise information, the unit minimum draught at site, in m, is to be obtained from the following formula:

$$T_{\text{mini}} = 0,03 L, \text{ without being greater than } 7,5 \text{ m}$$

where:

L : Rule length, in m as defined in Sec 2, [3.2.6].

1.3.8 Load definition criteria to be adopted in structural analyses of primary supporting members

This requirement applies for the definition of local loads to be used in the scantling checks of primary supporting members.

The most severe loading conditions and associated draught for the structural elements under investigation are specified in Sec 7.

For primary supporting members, a three-dimensional structural model is required.

2 Still water loads

2.1 Loading manual

2.1.1 A loading manual is to be submitted for approval.

The loading manual is, as a minimum, to be in compliance with the applicable requirements of Pt B, Ch 10, Sec 2, [2] and Pt B, Ch 10, Sec 2, [3] of the Ship Rules.

In addition, the requirements given in Pt D, Ch 1, Sec 5, [2.1.2] to Pt D, Ch 1, Sec 5, [2.1.8] of the Offshore Rules are to be satisfied.

2.2 Hull girder still water loads

2.2.1 Towing/transit and site loads

The hull girder still water loads as per [2.2.2] and [2.2.3] are to be defined for both towing/transit and on-site conditions. For this purpose, two distinct sets of still water bending moments and shear forces are to be specified.

2.2.2 Still water bending moment distribution

Design or allowable still water bending moment distribution is to be presented in a diagram or a table indicating the bending moment values at the longitudinal location of each compartment centre and at each transverse bulkhead.

2.2.3 Still water shear force distribution

Design or allowable still water shear force distribution is to be presented in a diagram or a table indicating the shear force values at each transverse bulkhead.

2.3 Loading instrument

2.3.1 The loading instrument is to be in accordance with the requirements of Pt B, Ch 10, Sec 2, [4] of the Ship Rules. Units covered by this Rule Note are to be considered as belonging to "Category I ships" as defined in Pt B, Ch 10, Sec 2 [2].

2.3.2 The loading instrument is also to perform stability calculations according to the procedures indicated in the Ship Rules as referenced above.

3 Wave loads

3.1 Towing/transit and site conditions

3.1.1 Wave loads defined in Article [3] are to be processed for both towing/transit and on-site conditions. For this purpose, two distinct sets of design wave loads are to be considered.

3.2 Design wave loads

3.2.1 Definitions

The following terms are used to describe the wave loads:

- wave load values:

wave load parameters constant along the length of the unit (unit motions and accelerations).

- wave load distributions:

wave load parameters varying along the length of the unit (hull girder wave loads, relative wave elevation).

3.2.2 Determination of the design wave loads

The design values and distributions of wave loads are to be determined as per Pt D, Ch 1, Sec 5, [3.2] of the Offshore Rules.

3.3 Hull girder wave loads

3.3.1 Vertical wave bending moment

The vertical wave bending moment at any hull transverse section in upright ship condition is to be obtained as required in Pt D, Ch 1, Sec 5, [3.3.1] of the Offshore Rules.

3.3.2 Horizontal wave bending moment

The horizontal wave bending moment at any hull transverse section is to be obtained as required in Pt D, Ch 1, Sec 5, [3.3.2] of the Offshore Rules.

3.3.3 Vertical wave shear force

The vertical wave shear force at any hull transverse section is to be obtained as required in Pt D, Ch 1, Sec 5, [3.3.3] of the Offshore Rules.

3.4 Unit motions and accelerations

3.4.1 Absolute motions and global accelerations

Rule values of the unit absolute motions and global accelerations are to be determined according to Pt D, Ch 1, Sec 5, [3.4] of the Offshore Rules taking into account the following values for GM, when not known from loading manual or Trim and Stability Booklet:

- 0,07 B for full loading condition
- 0,18 B for the other loading conditions.

3.4.2 Local accelerations

The design values of total longitudinal, transverse and vertical accelerations at any point are obtained from Pt D, Ch 1, Sec 5, [3.6.1] of the Offshore Rules, for upright and inclined ship conditions and based on the design unit absolute motions and global accelerations.

Note 1: As an alternative, the local accelerations directly calculated by hydrodynamic analysis may be specially considered by the Society.

3.5 Relative wave elevation

3.5.1 Design distributions

The design distributions of the relative wave elevation in upright and inclined ship conditions are obtained from Pt D, Ch 1, Sec 5, [3.5] of the Offshore Rules.

4 Load cases

4.1 Towing/transit and site conditions

4.1.1 Load cases defined in [4.2] are to be processed for both towing/transit and on-site conditions.

4.2 Load cases for structural analyses

4.2.1 Load cases to be considered according to the type of structural analysis are to be in accordance with Pt B, Ch 5, Sec 4, [1] of the Ship Rules.

However the wave loads and hull girder loads to be considered in each load case are defined in Pt D, Ch 1, Sec 5, [4] of the Offshore Rules.

5 Sea pressures

5.1 General

5.1.1 The sea pressures to be taken into account are those given in this Article [5].

However the Society may accept calculations based on pressures coming directly from hydrodynamic calculation, if duly justified.

5.2 Towing/transit and site conditions

5.2.1 Sea pressures defined are to be processed for both towing/transit and on-site conditions. For this purpose, two distinct sets of sea pressures are to be calculated.

5.3 Still water pressure

5.3.1 Still water pressure on sides and bottom, and pressure on exposed decks are to be calculated according to Pt B, Ch 5, Sec 5, [1] of the Ship Rules.

5.4 Wave pressure

5.4.1 Upright ship conditions

The wave pressure on sides, bottom and exposed decks in upright ship conditions at any point of the hull is to be calculated as required in Pt D, Ch 1, Sec 5, [5.4] of the Offshore Rules.

5.4.2 Inclined ship conditions

The wave pressure on sides, bottom and exposed decks in inclined ship conditions at any point of the hull is to be calculated as required in Pt D, Ch 1, Sec 5, [5.5] of the Offshore Rules.

6 Internal pressures

6.1 Towing/transit and site conditions

6.1.1 Internal pressures defined in are to be processed for both towing/transit and on-site conditions. For this purpose, two distinct sets of internal pressures are to be calculated.

6.2 Mass densities

6.2.1 Cargo mass density

The maximum mass density of each product stored and processed by the unit is to be indicated on drawings or in the loading manual.

Where the maximum mass density of the liquid carried is not given, the following values, in t/m^3 , are to be considered:

- $\rho_L = 0,50 t/m^3$ for methane
- ρ_L according to Pt D, Ch 9, Sec 19, Tab 2 of the Ship Rules for the other products.

6.2.2 Sea water mass density

A sea water mass density of $1,025 t/m^3$ is to be considered.

6.3 Calculations

6.3.1 Internal pressures

The internal still water pressure and the internal inertial pressure for all types of tanks and at any point are to be calculated following the provisions of Pt D, Ch 1, Sec 5, [6.3.1] and Pt D, Ch 1, Sec 5, [6.3.2] of the Offshore Rules.

6.3.2 Pressure for swash bulkheads

The still water and inertial pressures transmitted to the swash bulkhead structures are calculated according to Pt B, Ch 5, Sec 6, [1.2.1] of the Ship Rules.

6.3.3 Partly filled tanks

For units intended to be granted the additional service feature **SLOSHING**, as defined in Sec 2, [2.1.2], all cargo tanks are to be checked for several relevant partial filling levels. A direct sloshing calculation is to be submitted to the Society, as required in Sec 10, Tab 1.

Note 1: Guidelines for sloshing calculations are given in NI 554, Design Sloshing Loads for LNG Membrane Tanks.

Note 2: Subject to the agreement of the Society, direct sloshing calculation need not be performed for site areas where the extreme 100 years return period significant wave height is less than 1.5m.

6.3.4 Accommodations

The still water and inertial pressures transmitted to the deck structures are to be calculated as required in Pt D, Ch 1, Sec 5, [6.5] of the Offshore Rules.

6.3.5 Flooding

The requirements of Pt D, Ch 1, Sec 5, [6.6] of the Offshore Rules are to be complied with.

6.3.6 Testing

Testing still water and inertial pressures are to be calculated in accordance with Pt D, Ch 1, Sec 5, [6.7] of the Offshore Rules.

SECTION 6

STRUCTURE DESIGN PRINCIPLES

1 Structural principles

1.1 General

1.1.1 Units covers by the present Rule Note are to comply with the general principle requirements given in Pt B, Ch 4 of the Ship Rules.

1.2 Typical arrangement

1.2.1 Large openings in web frames and stringers should be verified and necessary documentation/calculation notes are to be submitted to the Society.

2 Materials for construction

2.1 General

2.1.1 Materials for construction are to comply with the requirements given in Pt D, Ch 9 Sec 6 and Pt B, Ch 4, Sec 1 of the Ship Rules.

3 Welding and weld connections

3.1 General

3.1.1 Welding and weld connections are to comply with the requirements given in Pt D, Ch 9, Sec 6 and Pt B, Ch 11, Sec 1 of the Ship Rules.

4 Mooring fittings and foundations

4.1 General

4.1.1 Mooring fittings (such as fairleads, bits, bollards or stoppers) and foundations are to be in accordance with Sec 4, [7.3] of NR493, Classification of Mooring Systems for Permanent and Mobile Offshore units.

Note 1: This requirement does not cover the ship-to-ship mooring equipment.

5 Reinforcements in way of supporting structures for hull attachments

5.1 Local arrangement

5.1.1 Generally, the supports for attachments and appurtenances are to be fitted in way of longitudinal and transverse bulkheads or in way of deck beams. Other supports are to be fitted in way of large primary supporting members.

The main structure may be locally reinforced by means of insert plates.

When the supports are only located on transverse web beams, the longitudinal structure is to be adequately reinforced.

The cut-outs in the deck transverses for the passage of ordinary stiffeners are to be closed in way of supports.

Particular attention is to be paid to buckling below supports.

6 Access

6.1 Access manual

6.1.1 An access manual is to be incorporated in the operating manual of the unit. The access manual is to describe unit's means of access to carry out overall and close-up inspections and thickness measurements.

6.1.2 The access manual is to be updated as necessary, and an up-dated copy is to be maintained onboard.

6.1.3 The access manual is to include, for each space, the following information:

- plans showing the means of access to the space, with appropriate technical specifications and dimensions
- plans showing the means of access within each space to enable an overall inspection to be carried out, with appropriate technical specifications and dimensions; the plans are to indicate from where each area in the space can be inspected
- plans showing the means of access within each space to enable close-up inspection to be carried out, with appropriate technical specifications and dimensions; the plans are to indicate the position of structural critical areas, whether the means of access are permanent or portable and from where each area can be inspected.

Note 1: Critical structural areas are locations identified from calculations to require monitoring, or, from the service history of similar or sister units, to be sensitive to cracking, buckling, deformation or corrosion which would impair the structural integrity of the unit.

- instructions for inspecting and maintaining the structural strength of all means of access and means of attachment, taking into account any corrosive atmosphere that may be within the space
- instructions for safety guidance when rafting is used for close-up inspections and thickness measurements
- instructions for the rigging and use of any portable means of access in a safe manner
- an inventory of all portable means of access
- records of periodical inspections and maintenance of the unit's means of access.

SECTION 7

STRUCTURE STRENGTH

1 Application

1.1 Units with the service notation liquefied gas carrier - FSRU

1.1.1 The structural strength under navigation condition is to comply with Pt B, Ch 6, Pt B, Ch 7 and Pt D, Ch 9, Sec 4 of the Ship Rules taking into account the design loads defined in Pt B, Ch 5 of the Ship Rules.

1.1.2 When the navigation condition covers the site conditions it is not necessary to evaluate the structural strength on-site and Articles [2] and [3] are not applicable.

Otherwise, if the site condition is more severe than the navigation conditions, the hull girder strength and the hull scantlings are to be evaluated, as defined in Articles [2] and [3] with the design loads defined in Sec 5, in addition to the requirement [1.1.1].

1.1.3 The fatigue assessment is to comply with the requirements given in Article [4].

1.2 Units with the service notation FSRU

1.2.1 For on-site conditions, the structural strength is to comply with the requirements given in Articles [2] and [3] with the design loads defined in Sec 5.

1.2.2 The structural strength is to be evaluated independently for the towing/transit phases covered by classification and the on-site conditions, with the design loads defined in Sec 5.

1.2.3 The fatigue assessment is to comply with the requirements given in Article [4].

2 Hull girder strength on-site

2.1 Application

2.1.1 In case of units with the service notation **Liquefied gas carrier - FSRU**, this Article need not be applied in case the navigation condition covers the site condition, as defined in [1.1.2].

2.1.2 The hull girder transverse sections are to comply with Pt B, Ch 6, Sec 1 of the Ship Rules taking into account the requirements of the present Article and the design loads defined in Sec 5.

2.2 Strength characteristics of the hull girder transverse sections

2.2.1 The strength characteristics of the hull girder transverse sections are to comply with Pt B, Ch 6, Sec 1 of the Ship Rules taking into account the design loads defined in Sec 5.

2.3 Yielding checks

2.3.1 The yielding strength are to comply with Pt B, Ch 6, Sec 2 of the Ship Rules taking into account the design loads defined in Sec 5.

2.4 Ultimate strength Check

2.4.1 The ultimate strength of the hull girder is to be checked according to Pt B, Ch 6, Sec 3 of the Ship Rules taking into account the partial safety factors defined in Tab 1 and the design loads defined in Sec 5.

Table 1 : Partial safety factors

Partial safety factor covering uncertainties on:	Symbol	On-site condition value	Transit condition value
Still water hull girder loads	γ_{S1}	1,00	1,00
Wave induced hull girder loads	γ_{W1}	1,25 (1)	1,10
Material	γ_m	1,02	1,02
Resistance	γ_R	1,10	1,03
<p>(1) If the vertical wave bending moment M_{WV} considered is derived from hydrodynamic calculations with a 10 000 years return period, the partial safety factor γ_{W1} may be reduced to 1,00. In this case, the product $\gamma_{W1} \times M_{WV}$ defined above with 10 000 years RP is not to be less than 1.25 M_{WV} derived with 100 years RP.</p>			

3 Hull Scantling on-site

3.1 General

3.1.1 In case of units with the service notation **Liquefied gas carrier - FSRU**, this Article need not be applied in case the navigation condition covers the site condition, as defined in [1.1.2].

3.1.2 The hull scantlings are to comply with Pt B, Ch 7 of the Ship Rules taking into account the requirements of the present Article and the design loads defined in Sec 5.

3.2 Plating

3.2.1 General

Plating are to be in accordance with the provision of Sec 6, [2] of NR542, Classification of Floating Gas Units.

3.3 Ordinary stiffeners

3.3.1 General

Ordinary stiffeners are to be in accordance with the provision of Sec 6, [3] of NR542, Classification of Floating Gas Units.

3.4 Primary supporting members

3.4.1 General

Primary supporting members are to be in accordance with the provision of Sec 6, [4] of NR542, Classification of Floating Gas Units.

4 Fatigue check of structural details

4.1 General

4.1.1 The design fatigue life of the unit is to be specified by the party applying for classification, and to be indicated on the midship section drawing.

By default the design fatigue life is to be greater than 20 years.

4.2 Structural details

4.2.1 The structural details to be checked are those defined in Pt D, Ch9, Sec 4, [5.7] of the Ship Rules.

4.2.2 In addition, the following structural details are to be checked:

- regasification plant connection with the main deck
- crane pedestal, if relevant
- mooring integration structure with hull (turret, buoy or spread mooring)
- turret: the long term distribution of forces is to be submitted by the turret designer (if relevant).

4.3 Units with service notation Liquefied gas carrier - FSRU

4.3.1 For units with the service notation **Liquefied gas carrier - FSRU**, the fatigue damage is a combination between the fatigue damage on navigation condition, as defined in [4.3.2], and the fatigue damage on-site condition, as defined in [4.3.3].

Hypothesis for the fraction of time for each condition is to be specified by the party applying for classification.

The damage combination is to be calculated using the following formulae:

$$D_{\text{tot}} = \alpha_{\text{nav}} \times D_{\text{nav}} + (1 - \alpha_{\text{nav}}) \times D_{\text{site}}$$

Where:

α_{nav} : Fraction of time for the navigation condition

D_{nav} : Fatigue damage in navigation condition, as defined in [4.3.2]

D_{site} : Fatigue damage on site condition, as defined in [4.3.3].

4.3.2 For navigation condition, the fatigue damage is to be performed in accordance with the provisions of Pt D, Ch 9, Sec 4 of the Ship Rules and Pt B, Ch 7, Sec 4 of the Ship Rules, taking into account [4.1] and [4.2].

4.3.3 For on-site condition, the fatigue damage is to be performed taking into account the loading/unloading cycles and the wave load cycles.

4.4 Units with service notation FSRU

4.4.1 The fatigue assessment is to be performed in accordance with the provisions of Pt D, Ch 1, Sec 7, [6] of the Offshore Rules, taking into account [4.1] and [4.2].

SECTION 8

UNIT ARRANGEMENT

1 General

1.1.2 In general, units with the service notation **FSRU** are to comply with the requirements [1.1.1], as relevant.

1.1 Application

1.1.1 For units with the service notation **Liquefied gas carrier - FSRU**, unit arrangement are to comply with Part B of the Ship Rules, Pt D, Ch 9 of the Ship Rules and requirements given in Sec 10.

SECTION 9

CARGO CONTAINMENT

1 General

1.1 Application

The requirements related to cargo containment specified in Pt D, Ch 9, Sec 4 of the Ship Rules are applicable for units covered by the present Rule Note, except where specifically indicated otherwise in this Section.

2 Sloshing on-site

2.1 Partly filled tanks on-site

2.1.1 For units intended to be granted the additional service feature **SLOSHING**, as defined in Sec 2, [2.1.2], all cargo tanks are to be checked for several relevant partial filling levels. CFD calculation or test campaigns is to be carried out for verification of sloshing pressure to no filling limitation, when the FSRU is on operation site.

A direct sloshing calculation is to be submitted to the Society, as required in Sec 10, Tab 1.

Note 1: Guidelines for sloshing calculations are given in NI 554, Design Sloshing Loads for LNG Membrane Tanks.

Note 2: Subject to the agreement of the Society, direct sloshing calculation need not be performed for site areas where the extreme 100 years return period significant wave height is less than 1.5m.

3 Units with service notation Liquefied gas carrier - FSRU

3.1 Sloshing

3.1.1 In addition to the requirement given in Article [2], the sloshing loads on cargo containment system and internal components are to be evaluated, as defined in Pt D, Ch 9, Sec 4, [3], based on the standard filling levels for the navigation condition (full load condition and ballast condition).

SECTION 10 REGASIFICATION PLANT (REGAS)

1 General

1.1 Application

1.1.1 Additional class notation **REGAS** is assigned to units when the design, construction and testing of regasification plant are in compliance with the requirements of this Article.

1.2 Principal

1.2.1 Regasification plant might include the following main components but not limited to:

- low pressure liquefied natural gas transfer pump (See Note 1)
- boil off Gas compressor (see Note 1)
- boil off recondenser tank or suction drum (see Note 1)
- high pressure liquefied natural gas pump or send out pump

- liquefied natural gas heat exchanger or vaporizer
- gas metering and analyzer skid
- associated liquefied natural gas and gas pipes and fittings including main send out gas manifold
- gas off-loading system
- associated automation systems
- utilities, heating medium systems (water glycol, refrigerant, steam or sea water)
- steel structure.

Note 1: Components might not be included on Regasification plant when already fitted on liquefied gas carrier system.

1.3 Documents to be submitted

1.3.1 Documents and drawings are listed in Tab 1 are to be submitted for information and/or approval.

Table 1 : Documents to be submitted

No.	A/I	Documents
1	I	Regasification operational philosophy (includes process and safety)
2	I	General arrangement of regasification plant
3	I	General arrangement of Unit including regasification plant layout
4	A	Regasification plant steel structure drawings and details
5	I	Slushing calculation, study for containment system, transfer pump mast and tower support
6	I	Process flow diagrams (PFD)
7	A	Piping and instrument diagrams
8	A	Single lines diagram and detailed diagrams of the electrical installations
9	I	Operational and maintenance manual
10	I	List of local authority requirement (if any)
11	A	Hazardous area plans
12	I	Risks assessment and analysis study reports
13	A	Fire and gas detection and alarm systems
14	A	Safety cause and effect diagram and chart
15	A	Passive and active fire protection systems (including Hull deck and regasification plant)
16	A	Escape route and evacuation plan
17	A	Arrangement and layout for protection against cryogenic leakage
18	A	Complete stress analysis of the piping system
19	I	Heat balance material calculation report
20	A	Description of the automation systems
21	A	Architecture diagram of the automation systems
22	A	Regasification workshops (FAT) and onboard operational test procedures
23	I	ESD philosophy arrangement

Note 1: A = to be submitted for approval

I = to be submitted for information

Note 2: The Society may require additional documents and plans based on project scenario and operational philosophy.

Note 3: No additional or duplication of documents are required to be submitted when above technical contents are already presented and included in typical standard unit's drawing.

1.4 Identified risk and hazards

1.4.1 In addition to typical HAZID and HAZOP study for liquefied natural gas storage unit, relevant hazard and risks scenarios with respect to regasification operation are to be identified (which might not be addressed by recognized code and Rule).

Such risks might include but not limited to:

- fire and explosion
- evacuation
- extension of hazardous areas
- pressurized gas discharge to shore
- process upset conditions
- high pressure gas venting
- storage and handling of flammable refrigerants, as relevant
- continuous presence of liquefied and vapour cargo outside the cargo containment system
- tank over-pressure and under pressure
- cryogenic liquid spillage
- collision risk during berthing manoeuvres
- dropped objects
- environmental pollutions and impacts.

According to the results of the HAZID and HAZOP study, specific risks analyses are to be carried out, if they are relevant.

Corresponding mitigation measures and provisions are to be taken and addressed and implemented accordingly on design (as defined in Sec 5, [1.3.6]), construction and testing.

Outcomes, provisions of risk assessment and studies are to be submitted to the Society and to be implemented on the design and drawings which are listed on Sec 2, [5].

Note 1: Risk analysis reports are considered for information only, to ensure that findings and conclusions of the risk analysis are properly taken into account for the design of the unit.

1.5 Layout

1.5.1 The layout of regasification plant or installation is to be designed giving due consideration to safety of personnel, prevention potential pollution, environment impact and protection of floating unit.

1.5.2 The installation is to be so arranged as to minimize the risk of occurrence of accident, risk of escalation, to protect manned spaces from consequences of accidents affecting other areas, ensure integrity of LNG storage and allow a safe evacuation when necessary.

1.5.3 Adequate provisions and arrangement should be made to facilitate safe access to control, cleaning and inspection on various places on regular basis during normal operation of regasification plant.

Arrangement should be made such that there is safe access at all times to valves that may need to be handled in normal operation.

1.5.4 Arrangement is to be made to have adequate lighting and ventilation when deemed necessary.

1.6 Structure

1.6.1 The steel structure of regasification plant is to be so designed and strengthened to support component weight and relevant forces including weather and sea dynamic motions in accordance with Sec 6 and Sec 7.

The local strength of the structure is to be assessed according to methods, codes or standards recognised to the satisfaction of the Society. Strength of plating under pressure loads is to be separately evaluated, using recognised codes or standards to the satisfaction of the Society.

Strength of lattice type structures is to be assessed using codes or standards recognised by the Society, such as American Institute of Steel Construction - Specification for Structural Steel for Buildings (AISC).

1.6.2 The regasification plant is to be protected from external forces and impact such as green sea water forces and dropped objects as relevant according to outcome of risk analysis required in [1.4.1].

1.6.3 The hull structure of the unit is to be protected against cryogenic release due to regasification plant operation. Relevant arrangement and plan based on location of sources of release is to be submitted.

1.6.4 Base on fire explosion risk analysis and study findings outcome according to [1.4.1] mitigation of risk of explosion to other places might require fitting of an insulated fire rated steel bulkhead.

1.7 Piping process safety features, mechanical integrity

1.7.1 Design pressure and design temperature are to be defined as stated in Pt C, Ch 1, Sec 10 of the Ship Rules.

1.7.2 Piping systems are to be protected against over pressure and over undesired temperature.

1.7.3 Fitting material of piping are to be in accordance with requirements of Pt D, Ch 9 of the Ship Rules.

1.7.4 Certification scheme of pipes and material is to be in accordance with [1.10].

1.7.5 Heating medium piping system is to comply with the requirements of Pt C, Ch 1, Sec 10 of the Ship Rules.

1.7.6 Process cause and effect chart is to meet minimum requirement of rule monitoring and control system including process shut down and emergency shutdown philosophy as per Tab 2.

1.7.7 Depressurizing manual and philosophy is to be submitted and to ensure safe operation of depressurizing while regasification plant is in normal operation, in process upset or shutdown mode.

1.7.8 Pumps and vaporizers or regas trains are to be fitted with isolating valves at the inlets and outlets.

Note 1: Alternative isolation philosophy and arrangement might accepted by Society in case base case basis providing Operator agreement.

Table 2 : Monitoring and control

Symbol Convention H = High, HH = High high, L = Low, LL = Low low, R = Remote, X = Function is required	Monitoring		Automatic Control			
			System		Auxiliary	
Identification of system parameter	Alarm	Indication	Shut-down	Control	Standby Start	Stop
LP Transfer Pump pressure	L	Local + R				
Recondenser tank or suction drum level	L + H	Local + R				
	LL		X			
Recondenser tank or suction drum pressure	L + H	Local + R				
BOG condenser liquid pressure	L + H	Local + R				
	HH		X			
HP send out pump pressure	L + H	Local + R		X		
	HH		X			
Vaporizer outlet gas pressure	L + H	Local + R		X		
Vaporizer outlet gas temperature	L + H	Local + R		X		
	LL		X			
Manifold/header pressure		Local + R				
Depressurizing mode	X					
Cryogenic spill detection	X					
Heating medium contaminated (LNG-Gas) detection	X					
Vaporizer heating medium inlet pressure	L + H	Local + R				
	LL		X			
Vaporizer heating medium inlet temperature	L	Local + R				
Vaporizer heating medium inlet flow	L		X			
Instrumentation supply failure	X		X			
Emergency shut down	X		X			
Gas detection system	X					
Fire detection system	X		X			

Note 1: Additional alarm and shut down control might be required based on HAZID/HAZOP recommendations and findings.

1.7.9 As practicable as possible, cryogenic pipes and pieces of equipment are to be located at the lowest level of plant.

1.8 Monitoring and control

1.8.1 The monitoring, controls, alarms and safeguards are to be provided in accordance with Tab 2.

1.9 Fire Safety features

1.9.1 General

When relevant, findings of risk assessment study required in [1.4.1] are to be considered and implemented on design and drawings which are listed on Tab 1.

1.9.2 Hazardous area

Extensions of hazardous area with respect to regasification plant configuration is to comply with requirements of Sec 12. Alternative arrangement may however be accepted for process parts of regasification plant, but justifications are to be provided.

1.9.3 Access arrangement and ventilation

In case of regasification plant installed on semi enclosed space, access arrangement and ventilation are to be in accordance with requirements of Pt D, Ch 9 of the Ship Rules.

If plant fitted on the open deck, then arrangement with adjacent space is to be agreed by society on case by case basis.

1.9.4 Fire passive protection system

Arrangement of fire passive protection and material documents are to be submitted.

1.9.5 Fire and Gas detection

The arrangement and layout of fire and gas detections are to be designed to cover regasification plant with respect to probability of presence of gas and fire risk. Such arrangement is subject to society approval.

Table 3 : Regasification components certification scheme

No	Item	Design assessment/ Approval	Raw material certificate	Examination and test	Product certificate
1	Steel plates, profiles, bars & pipes for main structure	-	C	-	C
2	Pipes and fittings	-	C	X	C
3	Expansion joint	TA	C	X	C
4	Flexible and loading/off-loading hoses	TA	C	X	C
5	Safety valves	TA	C	X	C
6	Cryogenic & Gas valves	TA	C	X	C
7	LP Transfer & HP send out pumps	DA	C	X	C
8	Heat exchanges, vaporizers	DA	C	X	C
9	Pressure vessels, suction drum	DA	C	X	C
10	Compressors	DA	C	X	C
11	Fire passive system and materials	TA	-	-	C/W
12	Fire active system	TA/DA	C/W	X	C
13	Gas detection system	TA	-	X	C
14	Cryogenic protection material	TA/DA	-	X	C
15	Electro motors	TA/DA	C/W	X	C
16	Automation systems	TA	-	X	C/W
17	Sensors, transmitters, flow meters, circuit breaker, electrical cable	TA	-	X	C/W
18	Heating media pump	TA/DA	W	X	C
19	Heating media pipes and fittings	-	-	-	-
	Class I & II	-	C	X	C
	Class III	-	W	-	W
20	Insulation material	TA	-	X	C/W
21	Gas metering/analyzer skid	DA	C	X	C
22	Boiler with associated components	TA/DA	C	X	C

Note 1: Abbreviations:
W : Work/manufacturer certificates
TA : Type Approval certificate (or MED Certificate) is required
DA : Design assessment is required
C : Class certificate is required
X : Classification intervention is required.

Note 2: In case a material or equipment is not listed, the requirement for survey as per NR266 is applicable.

1.9.6 Safety fire active system

Arrangement of fire fighting systems (fire main and hydrants, water spray systems and dry chemical powder) is to comply with the requirements of Pt D, Ch 9 of the Ship Rules.

1.9.7 Escape routes

At least two different escape routes are to be provided from the regasification plant.

Main escape routes are to be protected from green water effect.

Escape routes are to be protected against fire and sources of excessive heat.

1.10 Certification scheme

1.10.1 The requirement for survey of material and equipment covered by classification is given in Tab 3.

1.10.2 The certification scheme of materials and equipment covered by the Class, not list in Tab 3 is given in NR320, Certification Scheme of Materials and Equipment for the Classification of Marine Units.

1.11 Tests after installation onboard

1.11.1 This sub-article covers the tests to be carried out on board after installation of regasification plant. Onboard tests are intended to demonstrate that the plant with associated safety features is functioning properly in compliance with the Rules criteria. The tests are to be witnessed by a Surveyor.

1.11.2 Prior to commissioning of regasification plant, complete workshop tests and component certificates, pre-commissioning dossier is to be verified by surveyor to ensure compliance with Rule requirement and punch lists are closed.

1.11.3 The fire safety features of the regasification plant are to be operationally tested in the presence of surveyor.

1.11.4 Regasification process safety features are to be tested, including process upset simulation and emergency shut down functioning, according to approved test procedure, in the presence of a surveyor.

1.11.5 Upon completion of above satisfactory tests result, regasification operational test (including ESD functioning) is to be carried out in the presence of a surveyor.

1.12 References and codes

1.12.1 As reference only, a list of recognized regulations and standards relevant for regasification plant and components is given in Tab 4.

Table 4 : List of references and standards

Reference	Title
ASME Code Section VIII	Boiler and pressure vessel code
TEMA	Tubular exchanger manufacturer association
ASME B31.3	Process piping code
API 14C	Recommended practice for analysis, design, installation, and testing of basic surface safety systems for offshore production platforms
API 520 and API 521	Pressure relieving devices and depressurizing system
API 610	Centrifugal pumps for petroleum, heavy duty chemical and gas industry service
API 617	Axial and centrifugal compressors and expander compressors for petroleum compressors for petroleum, chemical and gas industry services
API 618	Reciprocating compressors for petroleum, chemical and gas industry services
API 619	Rotary type positive displacement compressors for petroleum, chemical and gas industry services
IEC 60092-502	Tankers - Special features
IEC 61285	Process control safety of analyser houses
EN 1474	Installation and equipment for liquefied natural gas, design and testing of marine transfer systems.
EN 1626	Valve for cryogenic service
EN 12434	Cryogenic flexible hose
EN 13275	Pumps for cryogenic service
IEC 60034	Rotating electrical machines
IEC 61892 series	Mobile and fixed offshore-electrical installation
IEC 60079-10	Classification of hazardous areas
Note 1: The latest version of reference and codes are to be addressed during design, construction, testing.	
Note 2: Alternative international code and standards might replace upon society agreement in case by case basis.	

SECTION 11

ELECTRICAL INSTALLATIONS

1 General

1.1 Application

1.1.1 The requirements related to electrical installations specified in Pt D, Ch 9, Sec 10 and Pt C, Ch 2 of the Ship Rule are applicable, except where specifically indicated otherwise in this section.

2 Hazardous locations and types of equipment

2.1 Electrical equipment permitted in gas-dangerous spaces and zones

2.1.1 In order to facilitate the selection of appropriate electrical apparatus and the design of suitable electrical installations, hazardous areas are divided into zones (0, 1 and 2) according to the definitions given in Sec 12, [1.3.4]. The different spaces are to be classified according to Sec 12, Tab 1. The types of electrical equipment permitted, depending on the zone where they are installed, are specified in Pt C, Ch 2, Sec 3 of the Ship Rules.

3 Units with service notation FSRU

3.1 General

3.1.1 For units with the service notation FSRU, provisions of Article [3] may be applied as an alternative to the requirements for supply systems from Pt D, Ch 9, Sec 10 of the Ship Rules.

3.2 Supply systems

3.2.1 The following parallel distribution systems with constant voltage may be used:

- a) on d.c. installations:
 - two-wire insulated (IT system)
 - two-wire with one pole earthed (TN system)
 - three-wire with middle wire earthed (TN system).
- b) on a.c. installations (primary distribution systems):
 - three-phase three-wire with insulated or impedance earthed (IT system)
 - three-phase four-wire with neutral directly earthed (TN system).
- c) on a.c. installations (secondary distribution systems):
 - three-phase three-wire with insulated or impedance earthed (IT system)
 - three-phase four-wire with neutral directly earthed (TN system)

- single-phase two-wire insulated (IT system)
- single-phase two-wire with one pole earthed (TN system)
- single-phase two-wire with mid-point of system earthed for supplying lighting and socket outlets (TN system)
- single-phase three-wire with mid-point earthed (TN system).

3.2.2 Where phase to neutral loads are to be served, systems are to be directly earthed (TN system).

Note 1: The neutral is defined for a polyphase only.

3.3 Impedance earthed distribution system

3.3.1 In the case of impedance earthing, the impedance is to be such that the earth fault current is slightly higher than the capacitive current of system. The maximum earth fault is however to be limited to:

- 100 A per generator
- 100 A per transformer.

3.3.2 Earth leakage monitoring and an alarm or automatic disconnection via earth leakage protection devices are to be provided.

3.4 Distribution systems in hazardous areas

3.4.1 If a power system with directly earthed neutral is used, it is to be of type TN-S with separate neutral and protective conductor. The neutral and the protective conductor are not to be connected together, or combined in a single conductor in a hazardous area.

Power system of type TN-C, having combined neutral and protective functions in a single conductor throughout the system, is not allowed in hazardous areas.

3.4.2 The electrical circuits and apparatus in hazardous areas, except intrinsically safe circuits and apparatus, are to be provided with means to ensure disconnection in the shortest practical time in the event of overload or short-circuit.

3.4.3 The electrical systems located in hazardous areas are to be further protected against earth fault as follows:

- a) IT system: alarm or automatic disconnection
- b) IT system with impedance earthed neutral: automatic disconnection in the shortest practical time
- c) TN-S system: automatic disconnection in the shortest practical time.

3.4.4 For installation in Zone 0, the following precautions are to be considered:

- a) earth fault currents in magnitude and duration is to be limited
- b) installation is to be disconnected instantaneously in case of the first fault, either by the insulation monitoring device or by a residual current device.

3.4.5 In insulated distribution systems, no current carrying part is to be earthed, other than:

- a) through an insulation level monitoring device
- b) through components used for the suppression of interference in radio circuits.

3.5 High voltage installations

3.5.1 Directly earthed neutral system is not to be used for high voltage installations.

3.5.2 Earthed neutral systems are admitted provided that the earth fault current is limited to an acceptable level, either by inserting an impedance in the neutral connection to earth or by an earthing transformer.

3.5.3 The earthing impedance is to be designed in order that:

- a) the resistive current is higher than the network capacitive current in the event of an earth fault, and

- b) the maximum earth fault current is limited to a value that the generators and transformers can withstand for a prolonged time without damage to the core (see Note 1), and
- c) the prospective earth fault current is at least three times the values of current required to operate any earth fault protective devices.

Note 1: The maximum earthing current is to be discussed with the equipment manufacturer. In the absence of precise values, the values specified in Tab 1 may be taken for guidance.

Table 1 : Recommended maximum earth fault currents

Rated voltage	Generator	Transformer
6,6 kV	20 A per generator	20 A per transformer
11,0 kV	20 A per generator	20 A per transformer

3.5.4 Efficient means are to be provided for detecting defects in the insulation of the system. For systems where the earth fault current exceeds 5 A, automatic tripping devices are to be provided. Where the earth fault current does not exceed 5 A, an indicator may be provided as an alternative to an automatic tripping.

3.5.5 In insulated earth system, any earth fault in the system is to be indicated by means of a visual and audible alarm.

3.5.6 In installations where outgoing feeders are not disconnected in case of an earth fault, the insulation of the equipment is to be designed for the phase-to-phase voltage.

SECTION 12

HAZARDOUS AREAS

1 General

1.1 General

1.1.1 This Section is applicable to hazardous areas due to cargo storage, LNG loading/off-loading and regasification plant.

1.1.2 All the requirements of this Section may be adapted, based on the finding and conclusions of the risk analysis report, defined in Sec 10, [1.4], which is to be submitted to the Society for information.

Detailed follow-up report of actions and mitigation measures taken in response to risk analysis findings is to be submitted to the Society for information.

1.2 General requirements

1.2.1 Where electrical equipment is installed in hazardous areas, it is to be selected, installed and maintained in accordance with standards not inferior to those acceptable to the Society. The types of electrical equipment admitted, depending on the zone where they are installed, are specified in Pt C, Ch 2, Sec 3, [10] of the Ship Rules. Equipment for hazardous areas is to be type approved by the Society. Automatic isolation of non-certified equipment on detection of a flammable gas is not to be accepted as an alternative to the use of certified equipment.

1.3 Definitions

1.3.1 Cargo area

The cargo area is that part of the unit which contains the cargo containment system, cargo pump room, compressor room, and includes deck areas above these spaces. Where fitted, the cofferdams, ballast or void spaces at the after end of the aftermost hold space or at the forward end of the forwardmost hold space are excluded from the cargo area.

1.3.2 Cargo control room

A cargo control room is a space used for the control of cargo handling operations.

1.3.3 Hold space

An hold space is a space enclosed by the unit structure in which a cargo containment system is located.

1.3.4 Hazardous areas, gas-dangerous spaces

Hazardous areas or gas-dangerous spaces are areas in which an explosive gas atmosphere is, or may be expected to be, present in quantities such as to require special precautions for the construction, installation and use of electrical apparatus.

Based upon the frequency and the duration of the occurrence of explosive atmosphere, hazardous areas are classified into the following zones:

- Zone 0:
 - an area where gas (or cargo) is present continuously or in which an explosive gas atmosphere is present continuously or is present for long periods
- Zone 1:
 - an area in which an explosive gas atmosphere is likely to occur in normal operation
- Zone 2:
 - an area in which an explosive gas atmosphere is not likely to occur in normal operations and, if it does, is likely to occur infrequently only and will exist for a short period only.

1.3.5 Explosive gas atmosphere

An explosive gas atmosphere is a mixture with air, under atmospheric conditions, of flammable substances in the form of gas, vapour or mist, in which, after ignition, combustion spreads throughout the unconsumed mixture.

2 Hazardous areas

2.1 Classification of hazardous areas due to storage, off-loading and regasification plant

2.1.1 For the purpose of machinery and electrical installations, hazardous areas are classified as indicated in Tab 1.

2.1.2 Alternative classification of hazardous area may be considered with justifications, based on IEC 60079-10 or equivalent to ensure that in case of leakage, the presence of an explosive gas atmosphere can be present only for a short period. This study shall cover all low and high pressure parts, liquid and vapour phases and is to be agreed by Society on case by case basis.

Table 1 : Description of spaces and hazardous area zones

No.	Space description	Hazardous area zone
1	The interior of cargo tanks, any pipework of pressure-relief or other venting systems for cargo, pipes and equipment containing the cargo or developing flammable gases and vapours	Zone 0
2	Interbarrier spaces, hold spaces where cargo is carried in a cargo containment system requiring a secondary barrier	Zone 0
3	Hold spaces where cargo is carried in a cargo containment system not requiring a secondary barrier	Zone 1
4	Cofferdams and permanent (for example, segregated) ballast tanks adjacent to cargo tanks	Zone 1
5	Cargo pump rooms and cargo compressor rooms	Zone 1
6	Enclosed or semi-enclosed spaces, immediately above cargo tanks (for example, between decks) or having bulkheads above and in line with cargo tank bulkheads, unless protected by a diagonal plate acceptable to the Society	Zone 1
7	Spaces, other than cofferdams, adjacent to, and below, the top of a cargo tank (for example, trunks, passageways and holds)	Zone 1
8	Areas on open deck, or semi-enclosed spaces on open deck above and in the vicinity of any cargo gas outlet intended for the passage of large volumes of gas or vapour mixture during cargo loading and ballasting or during discharging, within a vertical cylinder of unlimited height and 6 m radius centred upon the centre of the outlet, and within a hemisphere of 6 m radius below the outlet	Zone 1
9	Areas on open deck, or semi-enclosed spaces on open deck, within 1,5 m of cargo pump room entrances, cargo pump room ventilation inlet, openings into cofferdams, cargo compressor room entrances, cargo compressor room ventilation inlets or other zone 1 spaces	Zone 1
10	Areas on open deck within spillage coamings surrounding cargo manifold valves and 3 m beyond these ones, up to a height of 2,4 m above the deck	Zone 1
11	Areas on open deck over the cargo area where structures are restricting the natural ventilation and over the full breadth of the unit plus 3 m fore and aft of the forwardmost and aftermost cargo tank bulkheads, up to a height of 2,4 m above the deck	Zone 1
12	Compartments for cargo hoses	Zone 1
13	Spaces separated from a hold space, where cargo is stored in a cargo tank requiring a secondary barrier, by a single gastight boundary	Zone 1
14	Enclosed or semi-enclosed spaces in which pipes containing cargo products for boil-off gas fuel burning systems are located, unless special precautions approved by the Society are provided to prevent product gas escaping into such spaces	Zone 1
15	Cargo areas on open deck, or semi-enclosed spaces on open deck, within 3 m of any cargo tank outlet, gas or vapour outlet, cargo manifold valve, cargo valve, cargo pipe flange, cargo pump room ventilation outlets, cargo compressor room ventilation outlets and cargo tank openings for pressure release provided to permit the flow of small volumes of gas or vapour mixtures caused by thermal variations	Zone 1
16	Regasification areas on enclosed or semi-enclosed spaces, within 3 m of any gas or vapour outlet, valve, pipe flange, pump room ventilation outlets and compressor room ventilation outlets	Zone 1
17	Regasification areas on open deck, within 3 m of any gas or vapour outlet, valve, pipe flange, pump room ventilation outlets and compressor room ventilation outlets	Zone 1
18	Enclosed or semi-enclosed spaces in which pipes containing cargoes are located	Zone 1
19	Spaces 4 m beyond the cylinder and 4 m beyond the sphere defined in No. 8	Zone 2
20	Spaces forming an air lock as defined in NR467, Pt D, Ch 9, Sec 3, [1.6]	Zone 2
21	Areas on open deck extending to the coamings fitted to keep any spills on deck and away from the accommodation and service areas and 3 m beyond them up to a height of 2,4 m above the deck	Zone 2
22	Areas on open deck over the cargo area where unrestricted natural ventilation is guaranteed and over the full breadth of the unit plus 3 m fore and aft of the forwardmost and aftermost cargo tank bulkheads, up to a height of 2,4 m above the deck surrounding open or semi-enclosed spaces of zone 1	Zone 2
23	Spaces forward of the open deck areas referred to in 13 and 21, located below the level of the main deck and having an opening onto the main deck or at a level less than 0,5 m above the main deck, unless: <ul style="list-style-type: none"> • the doors and all openings are in non-hazardous area; and • the spaces are mechanically ventilated 	Zone 2
24	Areas within 2,4 m of the outer surface of a cargo tank where such a surface is exposed to the weather	Zone 2
25	Regasification areas on open deck, except areas defined in No 17, up to a height of 2,4 m above the upper skids level	Zone 2
26	Areas of 1,5 m surrounding a space of zone 1 defined in No. 15, No. 16 and No. 18	Zone 2

SECTION 13

MACHINERY, AUTOMATION AND FIRE PROTECTION

1 General

1.1 Application

1.1.1 For machinery, automation systems and fire protection, units with the service notation **Liquefied gas carrier - FSRU** are to comply with Part C of the Ship Rules and Part D, Chapter 9 of the Ship Rules.

1.1.2 In general, units with the service notation **FSRU** are to comply with the requirements [1.1.1], as relevant.

SECTION 14

SURVEY AND INSPECTION

1 General

1.1 Application

1.1.1 In general, units with the service notation **Liquefied gas carrier - FSRU** are surveyed in accordance with Ship Rules NR467 Pt A, Ch 3 and Pt A, Ch 4, Sec 5.

1.1.2 In general, units with the service notation **FSRU** are surveyed in accordance with Offshore Rules NR445 Part A, Chapter 2.

1.1.3 Upon request of owners and on a case by case basis, the Society may consider the acceptance of alternatives to these Rules, provided that they are deemed to be equivalent to the Rules to the satisfaction to the Society and, where relevant, accepted by Flag administration.

In such case a specific in-service inspection programme shall be approved by the Society and a memoranda is entered in the ship status.

2 Bottom surveys

2.1 General

2.1.1 For permanent installations and for other units where drydocking is impracticable, the examination of the outside of the unit's underwater parts and related items may be carried out during an in-water survey, subject to the notation **INWATERSURVEY** having been assigned and subject to the agreement of the Society and as authorised by Flag Administration and, when relevant, by the coastal state.

2.1.2 In principle, no outstanding recommendations are to exist requiring repair work to be carried out to the underwater part of the shell plating, the rudder, the propeller or the propeller shaft, unless the Society is satisfied that such repairs may be carried out while the ship is afloat.

2.1.3 Proposals for in-water survey are to be submitted in advance of the entry in service and the mandatory following surveys by the Owner so that satisfactory arrangements can be agreed with the Society and the Flag Administration.

The in-water survey is to be carried out with the ship in calm water and preferably with weak tidal streams and currents. The in-water visibility and the cleanliness of the hull below the waterline are to be clear enough to permit a meaningful examination allowing the Surveyor and the diver to determine the condition of the plating, the appendages and the welding.

The equipment, procedure for observing and reporting the survey are to be discussed with the parties involved prior to the in-water survey, and suitable time is to be allowed to permit the diving company to test all equipment beforehand.

2.1.4 The in-water survey is to be carried out, under surveillance of a Surveyor, by divers or by suitably equipped remotely operated vehicles (ROV's). The divers are to be employed by a firm approved as service supplier by the Society.

The in-water survey scope of work maybe mergeable over a three months period (weather condition, in-water visibility, diver's safety...). The overlap and the sequence of inspection shall be provided at satisfaction of the surveyor.

The Surveyor is to be satisfied with the methods of orientation of the diver(s) on the plating, which should make use where necessary of permanent markings on the plating at selected points and with the method of pictorial representation. An efficient two-way communication between the Surveyor and the diver(s) is to be provided.

2.1.5 The in-water survey is to provide the information normally obtained from a bottom survey in dry condition. Special consideration shall be given to ascertaining rudder bearing clearances and stern bush clearances of oil stern bearings based on a review of the operating history, on board testing and stern oil sample reports. These considerations are to be included in the proposals for in-water survey as required in [2.1.3].

During in-water survey, cathodic protection potential readings are to be taken. The amount of readings is to be representative of the whole immersed part of the structure of the unit.

Upon completion of the survey, the approved diving firm is to submit to the attending Society Surveyor a detailed report including video tapes, as well as a photographic documentation of the main parts inspected.

2.1.6 If the in-water survey reveals damage or deterioration that requires immediate attention, the Surveyor may require that the ship be drydocked in order that a detailed survey can be undertaken and the necessary repairs carried out.

2.1.7 A memoranda is to be entered in ship status.

2.1.8 On completion of the on-site FRSU assignment when the unit has been for five years or more, or has performed its latest renewal survey on site without drydocking and before re-location or to resume trading, a bottom survey in dry-dock is to be performed.

Note 1: Attention is also drawn to the relevant requirements concerning the application of national and international regulations.

3 Tailshaft surveys

3.1 General

3.1.1 Tailshafts surveys are done as per Pt A, Ch 3, Sec 5 of the Ship Rules. Special consideration may be given by the Society when the shaft is fitted with keyed propeller coupling.

In case of units with propulsion, the additional class notation **MON-SHAFT** is mandatory.

4 Mooring system

4.1 General

4.1.1 For units intended to be granted the additional service feature **POSA** or **POSA Jetty**, surveys of the permanent mooring system are to be done as per NR493 "Classification of Mooring Systems for Permanent Offshore Units".

4.1.2 Surveys of the temporary mooring equipment, if any, are to be done as per NR445 Pt A, Ch 2, Sec 8.

5 Design requirements for survey

5.1 General

5.1.1 When it is intended to have the intermediate and/or renewal survey performed while the unit is in continuous operation, the unit shall be adequately prepared to allow the relevant surveys and tests to be safely undertaken to the required extent, paying particular attention to safety valves, cargo pumps, regasification plant, electrical equipment in hazardous areas and inert gas system.

Where in-service inspection programme as per requirement [1.1.3] is approved then surveys and inspections according to this program are to be complied with.

5.2 Cargo tanks inspection

5.2.1 Arrangements are to be set out to allow safe inspection of a single or more cargo tanks with the unit in operation. Double shut off arrangement for all interconnections between tanks and equipment and piping to be fitted.

5.3 Cargo handling equipment

5.3.1 General

When inspection is required during the renewal survey, arrangements are to be made during the design stage to allow this testing when the plant is in operation.

5.3.2 Cargo pumps

Cargo pumps are to be dismantled for inspection during renewal survey. Arrangements are to be made during the design stage to allow this testing when the plant is in operation.

5.3.3 Safety valve

As required in , safety valve are to be tested every 5 years, arrangements are to be made during the design stage to allow this testing when the plant is in operation.

5.3.4 Regasification plant

Internal and external inspection of equipments (such as suction drum) are to be planned when the plant is in operation.

5.3.5 Electrical equipment

For each renewal survey, the electrical resistance of electrical equipment circuits are to be measured, while the cargo handling system is in operation.

Tests, exams and possible calibration of the different instrumentation and safety devices is to be foreseen.

5.3.6 Inert gas system

This system is to be overhauled and serviced during the renewal surveys, but precautions will be required during this period, in case a supply of inert gas is needed while the plant is shut down.

